

Haldex Coupling

The development of the Haldex coupling is a giant step forward in modern all-wheel-drive technology. The Haldex coupling is controllable, based on the inputs the Haldex control module receives from the vehicle.

Slip is no longer the only decisive factor in the distribution of drive forces; the car's dynamic state is also a factor. The Haldex control module monitors the ABS wheel speed sensors and the engine control module (accelerator pedal signal) via the CAN bus. This data provides the control module with all the information it needs on road speed, cornering, coasting or traction mode, and can respond optimally to any driving situation.

Characteristics of the Haldex coupling:

- Permanent all-wheel drive with electronically controlled multi-plate clutch
- Front drive characteristic
- Quick response
- No strain on clutch when parking and maneuvering vehicle
- Compatible with different tires (e.g. emergency wheel)
- No restrictions on towing with the rear axle on the ground
- Fully combinable with systems such as the anti-lock brake system (ABS), the electronic differential lock (EDL), the anti-slip regulation (ASR), the electronic brake distribution system (EBD) and electronic stabilization program (ESP)



Haldex Coupling

Haldex Coupling

The Haldex coupling is mounted on the rear axle differential and is driven by the prop shaft.

Engine torque is transmitted to the prop shaft through the gearbox, the front axle differential and the front axle drive.

The prop shaft is connected to the input shaft of the Haldex coupling. In the Haldex coupling, the input shaft is separated from the output shaft to the rear axle differential.

Torque can only be transmitted to the rear axle differential when the Haldex coupling clutch plates are engaged.

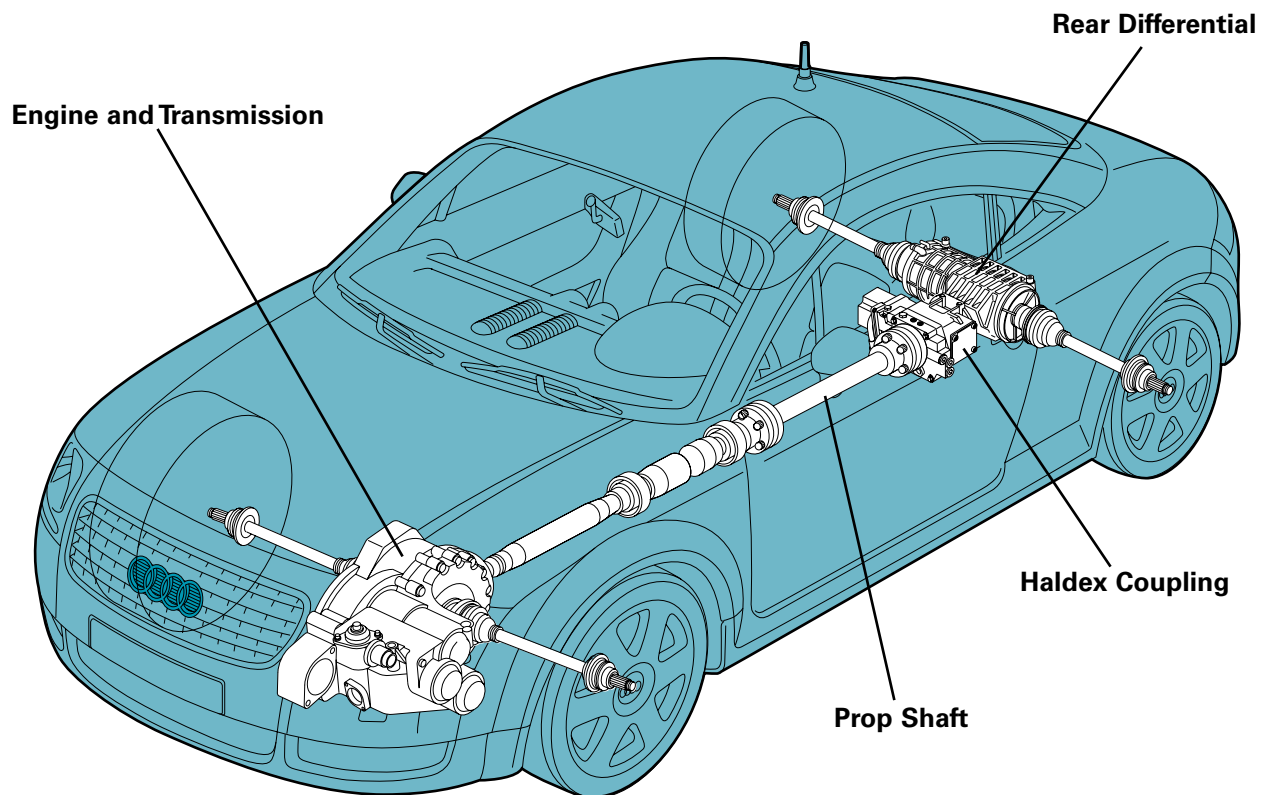
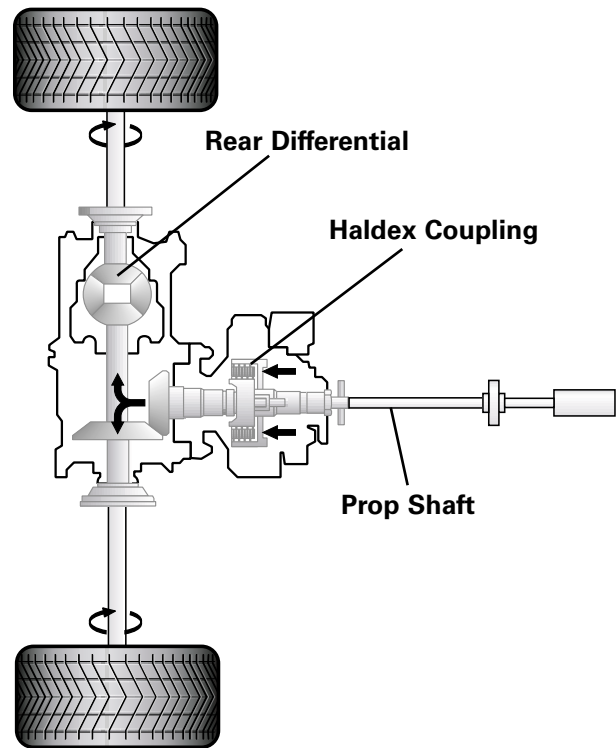

Haldex Coupling

Haldex System

The parts include:

- the input shaft
- the inner and outer clutch plates
- the lifting plate
- the roller bearing with annular piston
- the output shaft

The electronics are:

- the pump for Haldex coupling
- the regulating valve positioning motor
- the temperature sensor
- the Haldex control module

The hydraulics are:

- the pressure valves
- the accumulator
- the oil filter
- the annular piston
- the regulating valve

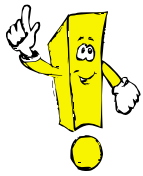

The Haldex oil and oil filter must be replaced every 20,000 miles (32,000 km). Refer to AESIS for the latest maintenance schedules and service procedures

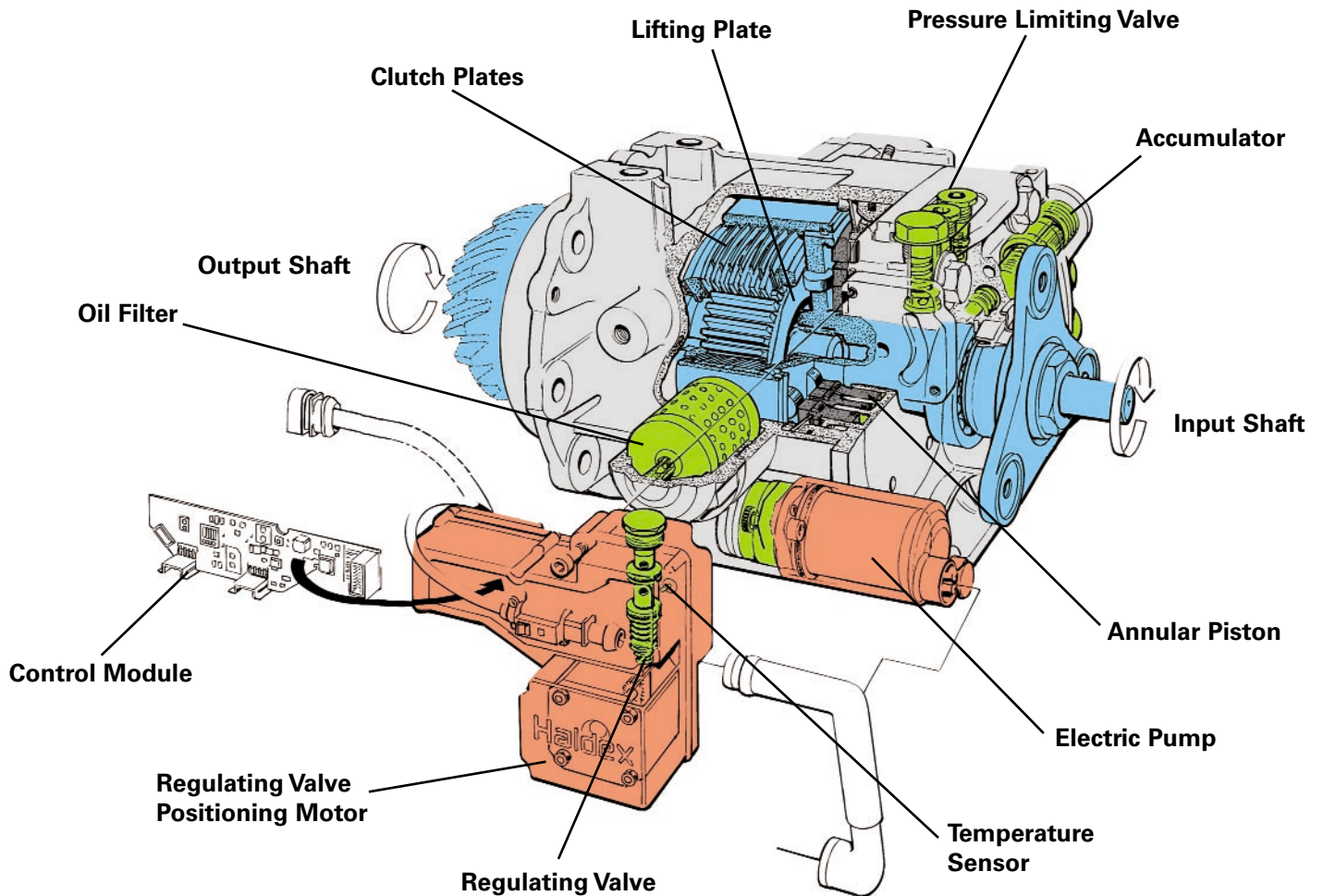

Haldex Coupling

The Multi-plate Clutch

The clutch input shaft, indicated in blue in the figure, is connected to the prop shaft. The roller bearings for the lifting piston and the working piston, as well as the outer clutch plates, are engaged when the input shaft rotates.

The lifting and working pistons are annular pistons. The output shaft, indicated in red in the figure, forms a unit from the lifting plate through to the drive pinion head. The inner clutch plates are also connected to the output shaft via longitudinal tothing.

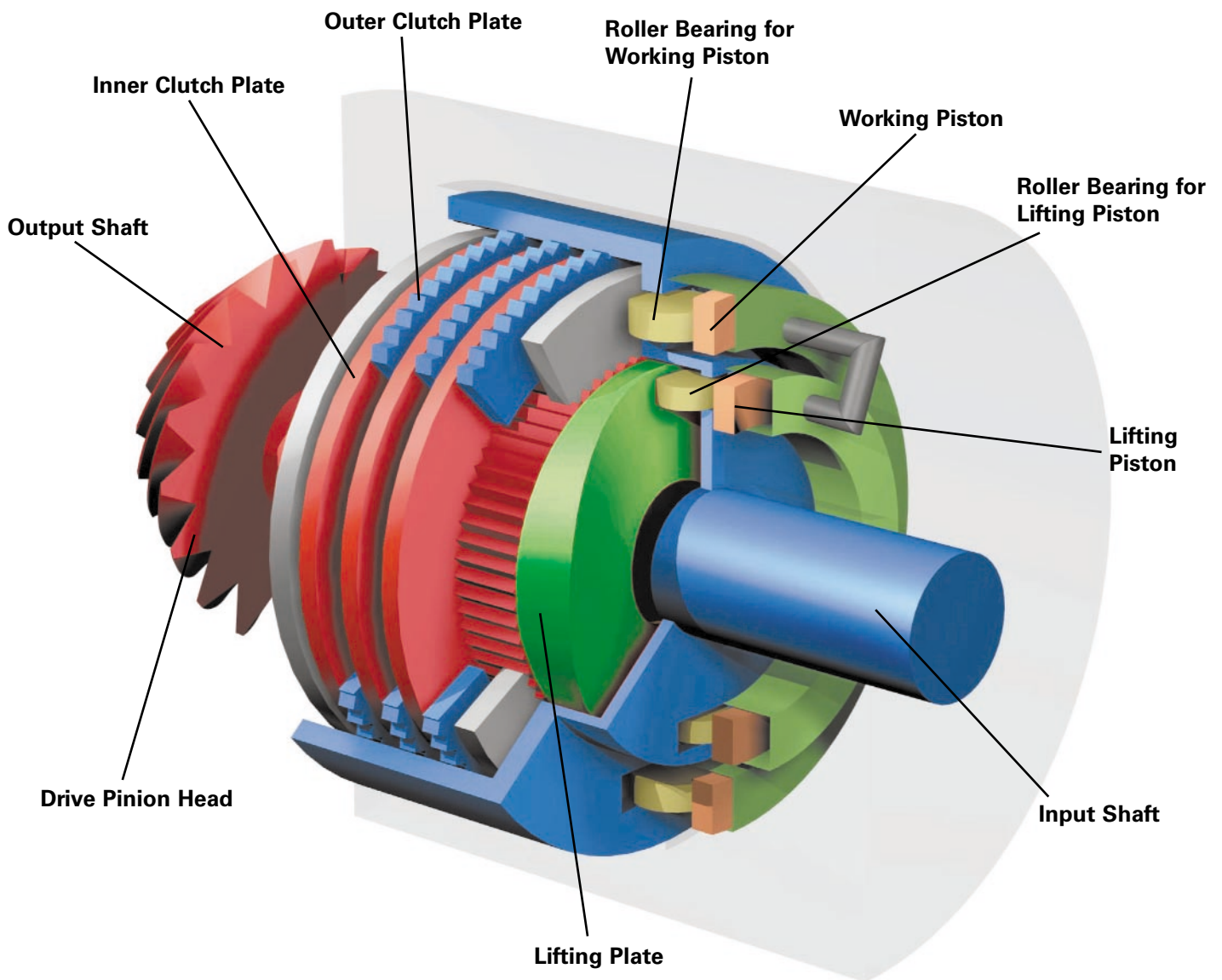

Disengaged Haldex Clutch Assembly

Haldex Coupling

Function

When a speed difference is present between the input and output shafts, the input shaft, together with the roller bearing of the lifting piston, rotates around the still stationary lifting plate of the output shaft.

The roller bearing of the lifting piston tracks along the undulating surface of the lifting plate. The roller transfers these upward and downward movements to the lifting piston.

This causes the lifting piston to perform a lift movement, building up oil pressure.

This oil pressure is diverted via an oil duct to the working piston. The oil pressure forces the working piston to move to the left against the bearing roller and the pressure plate of the clutch plate set.

The clutch plate set is compressed.

The input shaft and the output shaft of the clutch are now interconnected, connecting both the front and rear axles and making all-wheel drive possible.

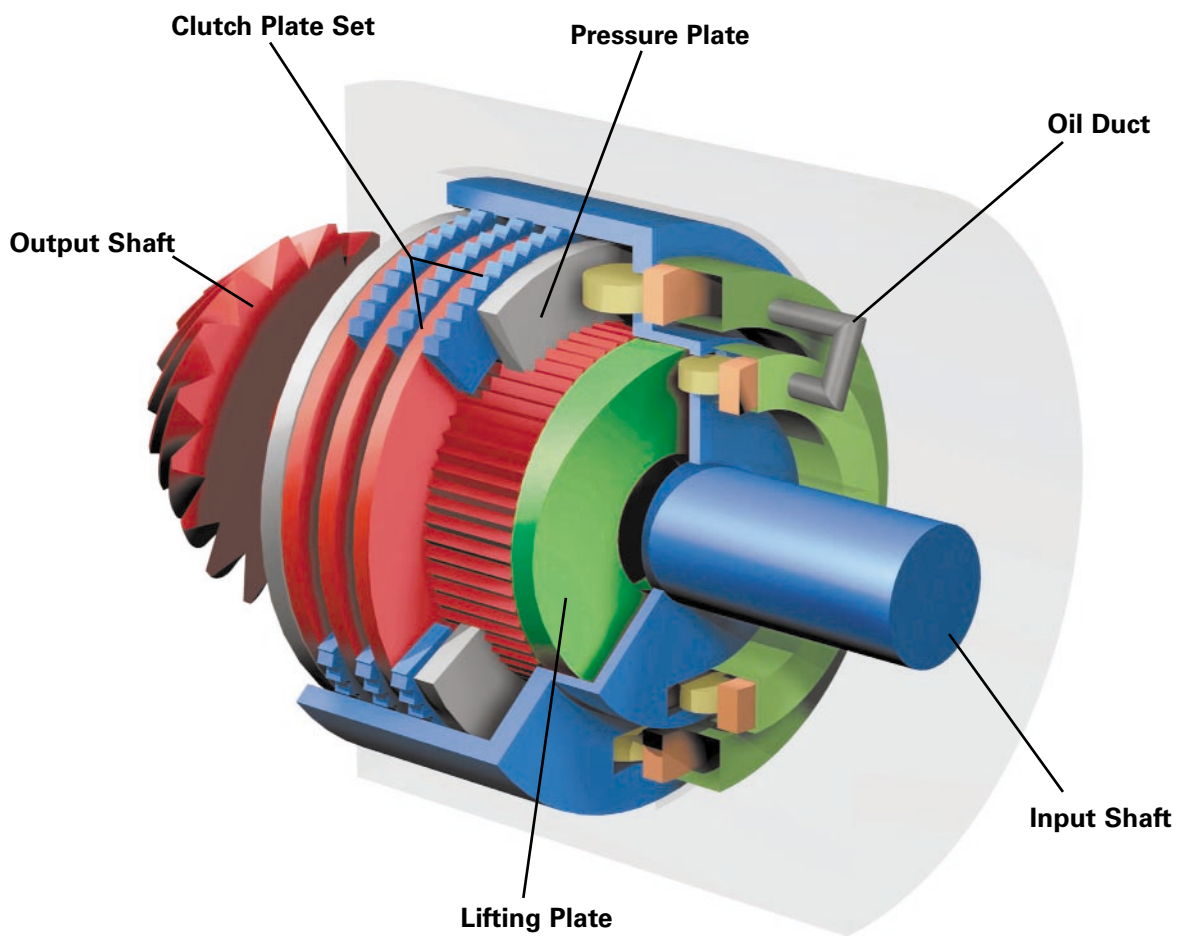

Engaged Haldex Clutch Assembly

Haldex Coupling

When a difference in speeds occurs between the front and rear axles, the outer clutch plate housing, together with the roller bearings, rotates around the output shaft in such a way that the roller bearings of the lifting piston roll on the lifting plate.

Due to the shape of the lifting plate, the roller bearings of the lifting piston follow an undulating path and transfer the lifting movement to the lifting pistons in the housing.

The output shaft, with its splines for the inner clutch plate, combines with the lifting plate and the drive pinion head to form a unit.

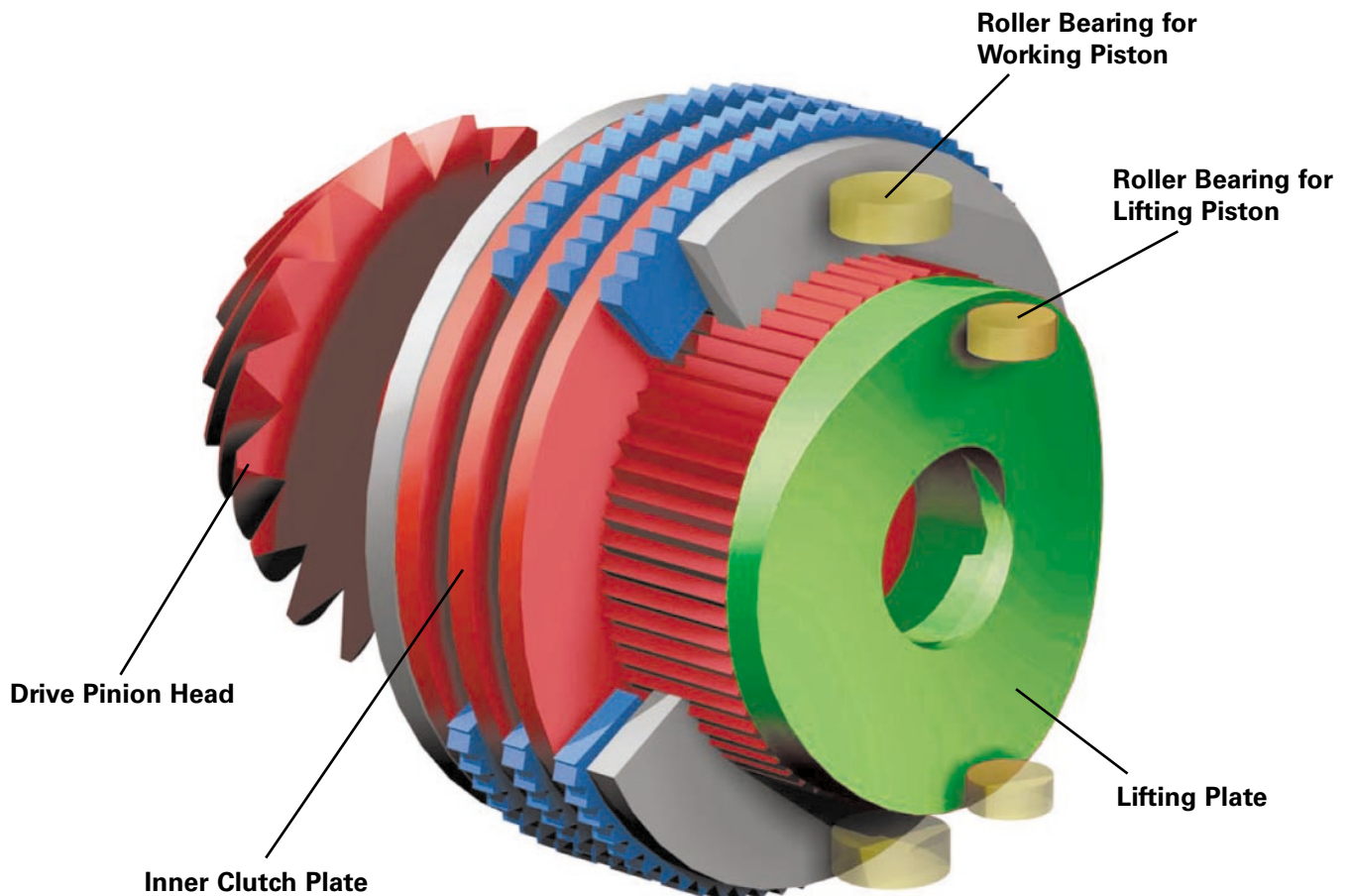

Engaged Haldex Clutch Assembly

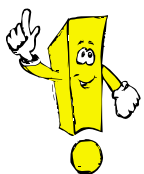

The roller bearings are shown here for your information only.

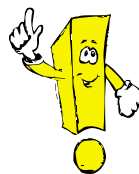

For reasons of clarity, we have shown the lifting plate with two cams. In reality, however, there are three cams on the lifting plate. The function remains unchanged.

Haldex Coupling

The outer clutch plate housing, together with the splines for the outer clutch plate and the roller bearing form, combines with the input shaft to form a unit.

The lifting movement of the lifting piston produces an oil pressure which acts on the working piston via the oil duct and pushes the piston to the left.

The pressure is transferred via a pressure plate to the clutch plate set via the roller bearings of the working piston. The clutch closes and thus interconnects the front and rear axles.

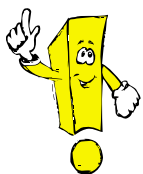
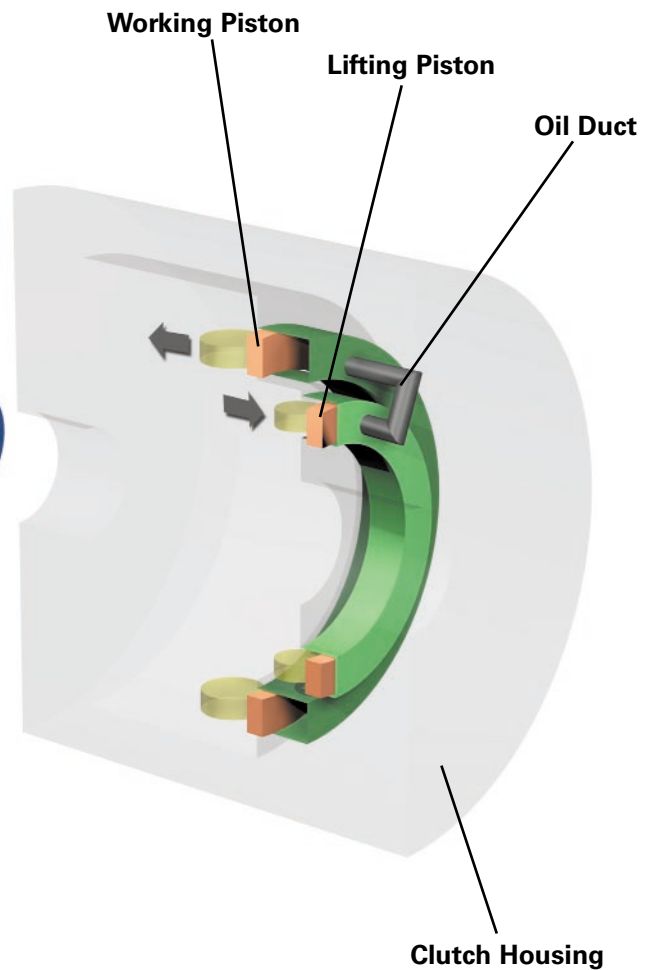
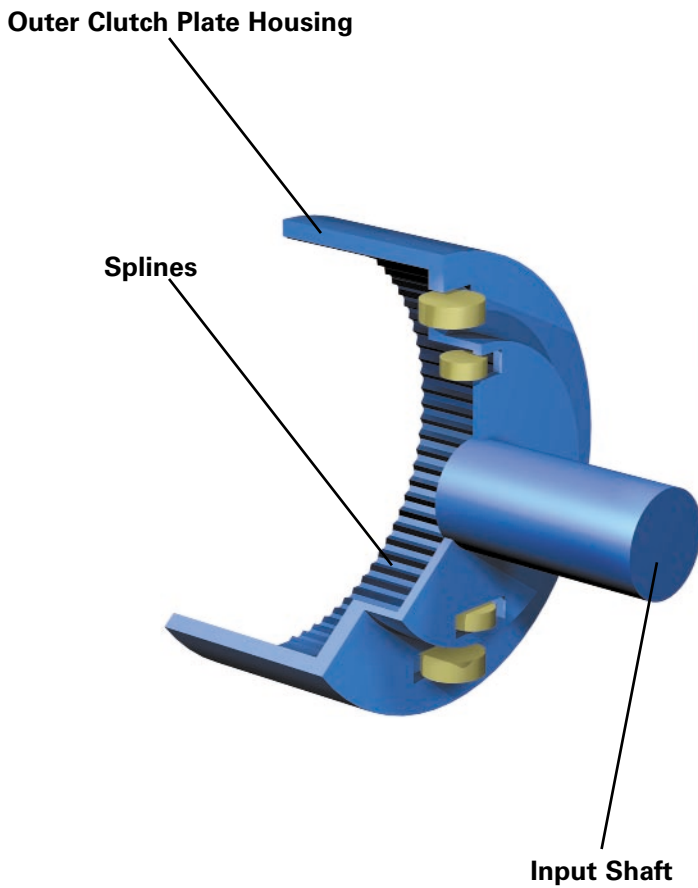

The roller bearings are located in the outer clutch plate housing, as shown here.

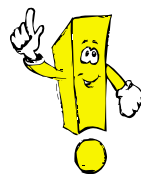

The roller bearings are shown here for your information only.

Haldex Coupling

Diagram of Oil Pressure System

The pressure limiting valve determines the maximum pressure on the clutch plates.

You have already seen how oil pressure is built up at the lifting piston as a result of a difference in speeds between the input shaft (blue) and the output shaft with lifting plate (red).

This oil pressure is regulated by valves. The plate clutch can thus allow a certain amount of slip when open and nearly closed.

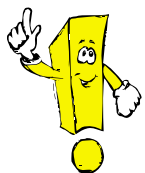
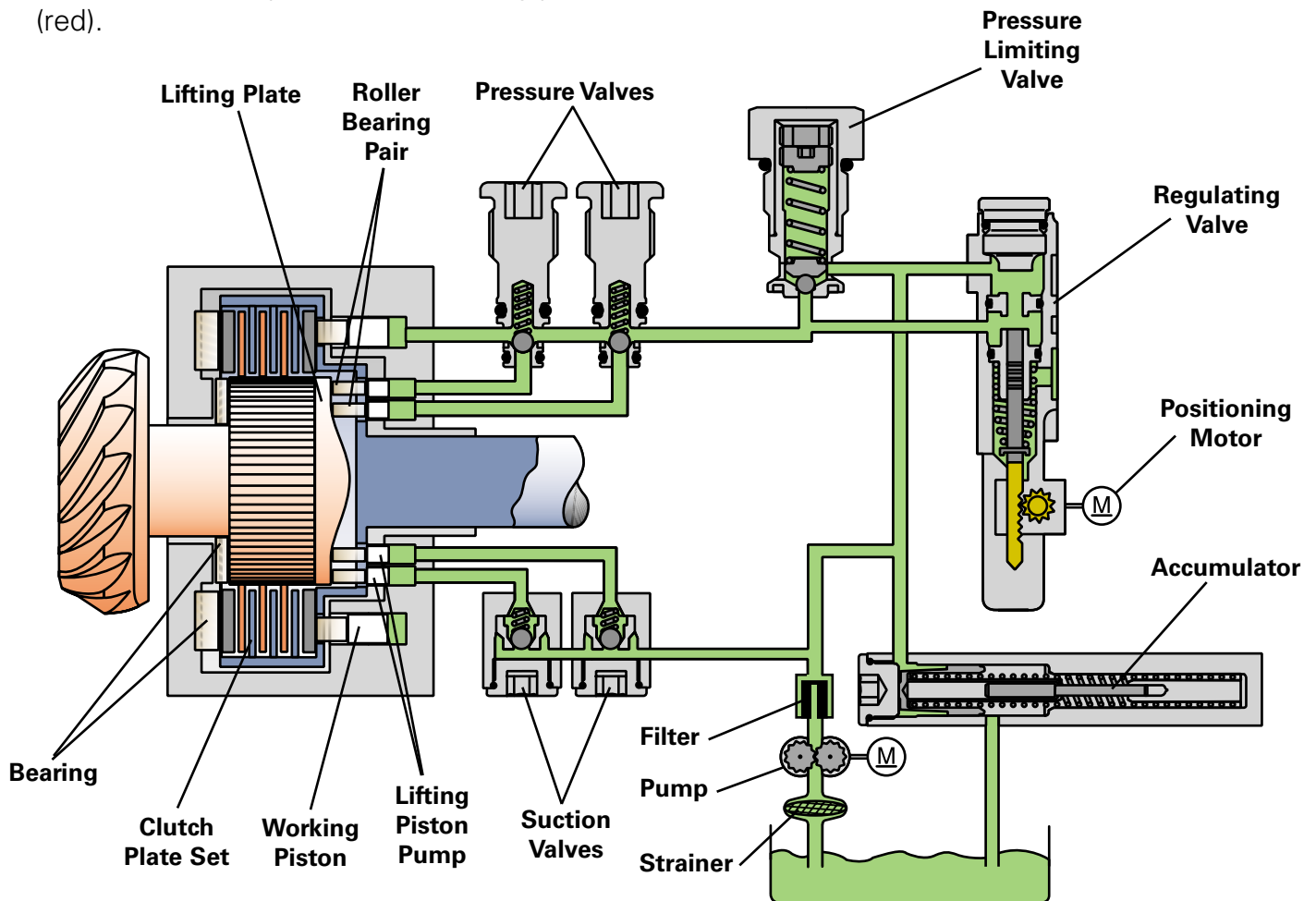

For reasons of clarity, we explained the function on the previous pages using a lifting piston by way of an example. In reality, there are two lifting pistons in the clutch housing; these pistons are actuated by roller bearing pairs. Therefore, two suction valves and two pressure valves are also required.

Haldex Coupling

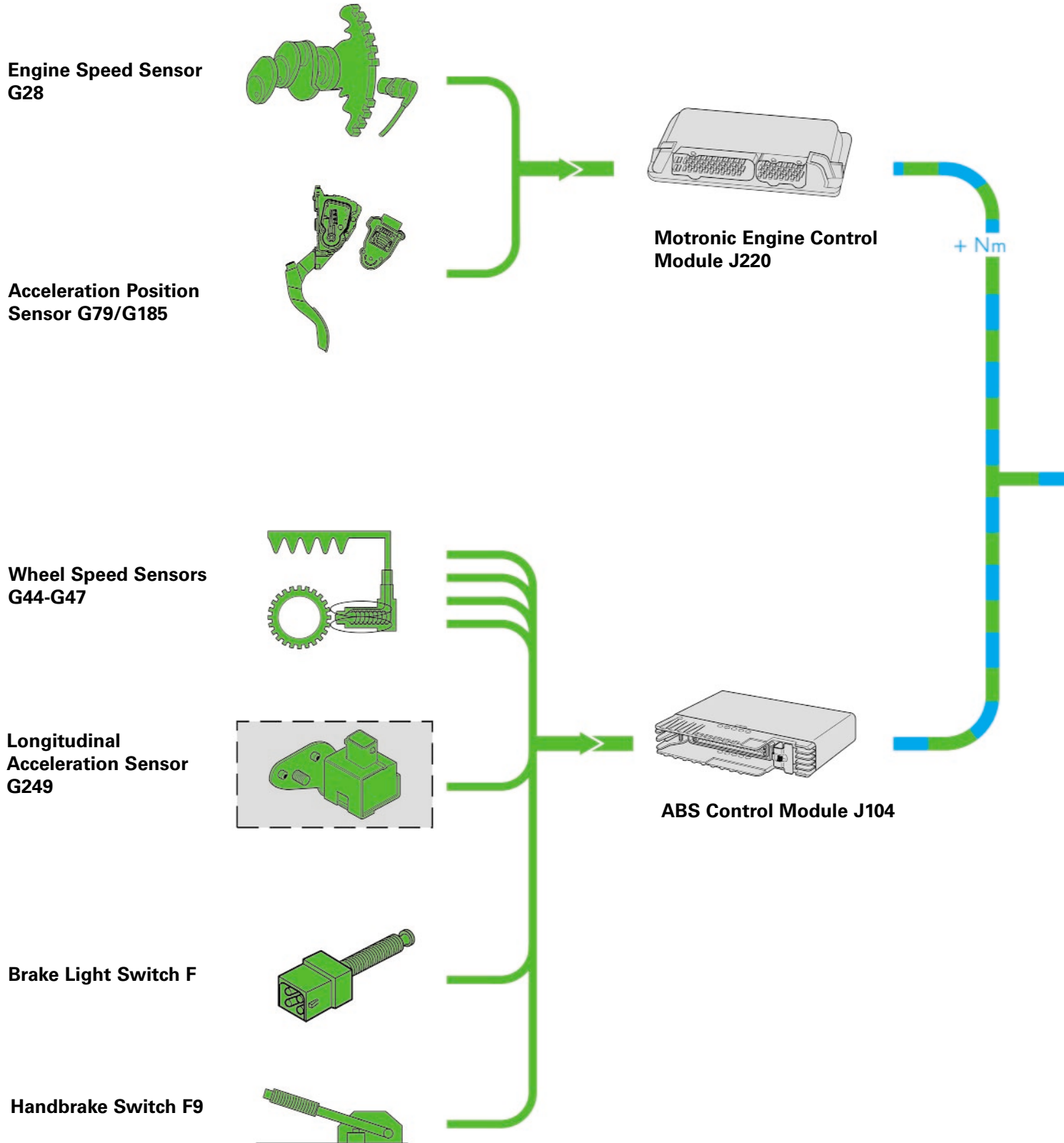

Haldex Coupling

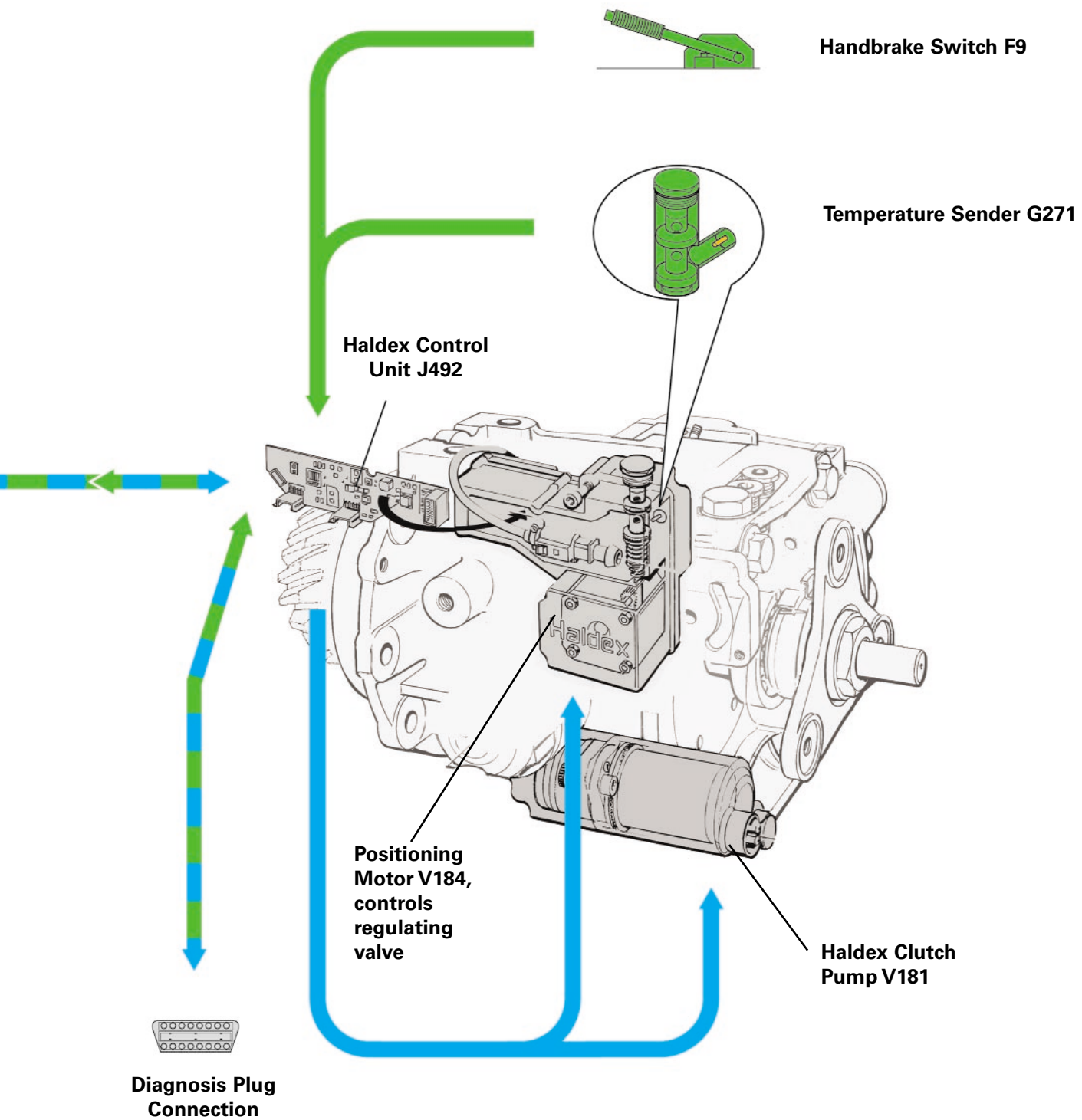

Haldex Coupling

The Motronic Engine Control Module

The Motronic engine control module (ECM) is mounted in different areas on the various vehicles, but is normally accommodated in the plenum chamber. The operating mode of the Motronic ECM is torque-oriented.

Signal utilization for the all-wheel drive electronics

The Motronic ECM provides the following signals to the Haldex control module along the CAN bus:

- Engine speed signal
- Accelerator pedal position
- Engine torque

Effects of signal failure:

- The Haldex unit will not operate

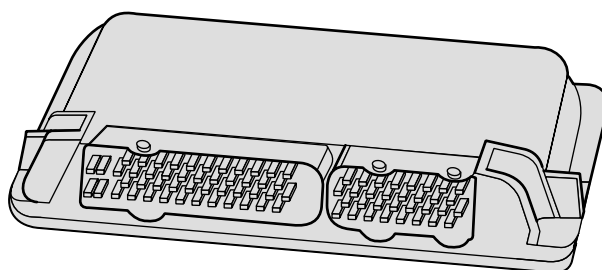

Motronic Engine Control Module J220

Engine Speed Sensor G28

The engine speed sensor is an inductive sensor and is installed near the the oil filter on the left-hand side of the engine.

Signal utilization

The sensor records the exact angular position of the crankshaft to determine the ignition and injection point, as well as engine speed.

Engine speed

As soon as the engine turns, the sensor wheel moves past G28 and generates an alternating current (AC) voltage. The frequency and amplitude of this voltage changes with engine speed.

The Motronic ECM calculates the engine speed from the frequency of the AC voltage.

Ignition point

For recognizing the crankshaft position, the wheel has a larger gap trigger tooth which serves as a reference mark.

Effects of signal failure

If the engine speed signal supplied by the engine speed sensor fails, the engine will not be started or run.

If no engine speed signal is received, the Haldex control module will not energize the pump, leaving the rear axle drive capability disabled. This also allows the vehicle to be towed with the rear wheels on the ground. No power will be transmitted back through the wheels to the transmission.

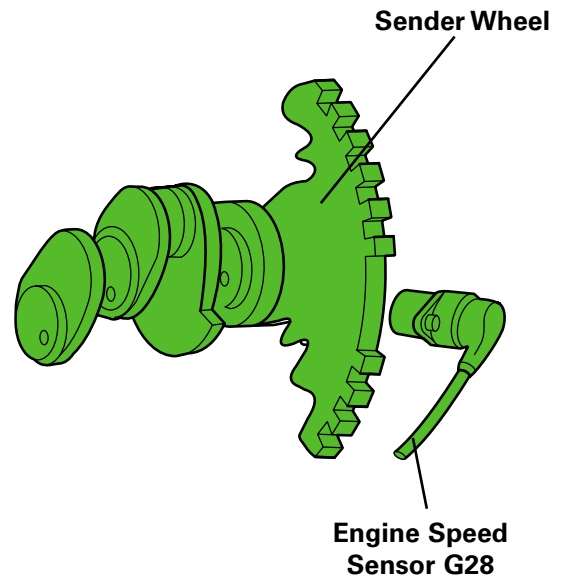

Electrical circuit

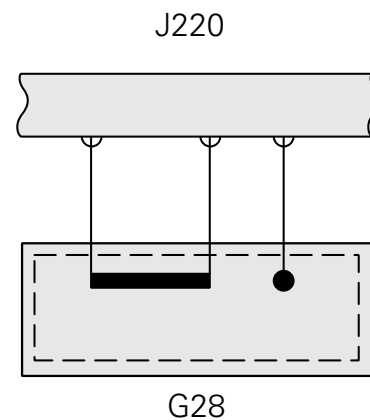

Haldex Coupling

Throttle Position Sensor G79/G185

The throttle position sensor sends an analog signal corresponding to the accelerator pedal position to the Motronic ECM. Two independent potentiometers, G79 and G185, make up the throttle position sensor.

The Haldex control module uses this signal in combination with other signals to determine when and how much power should be applied to the rear axle. The throttle position sensor represents the driver intention, and is not necessarily how the Motronic ECM is allowing the engine to operate.

Effects of signal failure

The Motronic ECM monitors G79 and G185 for proper functioning and plausibility. If one of the two sensors fails, the other sensor acts as a back-up. The warning lamp K132 on the instrument panel will illuminate and the vehicle will enter emergency running mode.

If this signal is not available to the Haldex control module, all-wheel drive will not be available.

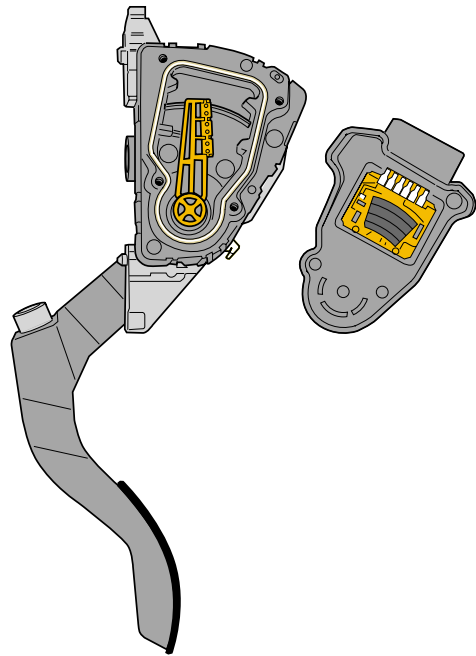

Throttle Pedal Position Sensor G79/G185

ABS Control Module J104

The anti-lock brake system (ABS) control module (by ITT Automotive) is combined with the hydraulic unit as a module and mounted in the engine compartment on the left-hand side.

When the ignition is turned on, the control modules carry out a self-test. The control module consists of two processor systems. This ensures a high level of fail-safety. In addition to monitoring individual components, the two processor systems monitor each other.

Signal utilization for all-wheel-drive electronics

The following signals are supplied to the Haldex control module along the CAN bus:

- Wheel speed sensor
- Brake light switch
- Handbrake switch
- Longitudinal acceleration sensor

Effects of signal failure

In the unlikely event of total failure of the control module, the Haldex unit will not function properly.

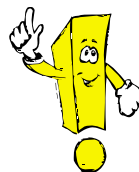
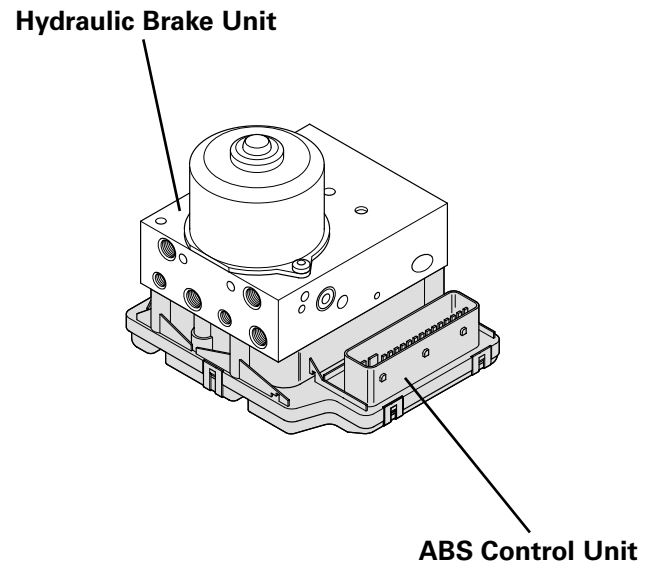

If the vehicle also has the electronic stabilization program (ESP), then ESP control takes precedence over the all-wheel drive function.

Haldex Coupling

Wheel speed sensors G44 - G47

The wheel speed sensor detects the change in speed of the wheel and sends this information to the ABS control module in the form of wheel speed information. This information is then sent to the Haldex control module via CAN-bus.

The wheel speed sensor is mounted in the vicinity of the axle flange. A toothed wheel is positioned on the axle flange in such a way that it moves past the top end of the wheel speed sensor when the wheel rotates.

Magnetic lines of force between the tooth and tooth gap of the toothed wheel are distorted. This induces a sine-wave AC voltage in the coil of the engine speed sensor.

The frequency and amplitude in the coil is dependent on the wheel speed. The ABS control module calculates the momentary speed of individual wheels from the frequency.

Effects of signal failure

- No ABS control
- No four-wheel-drive control

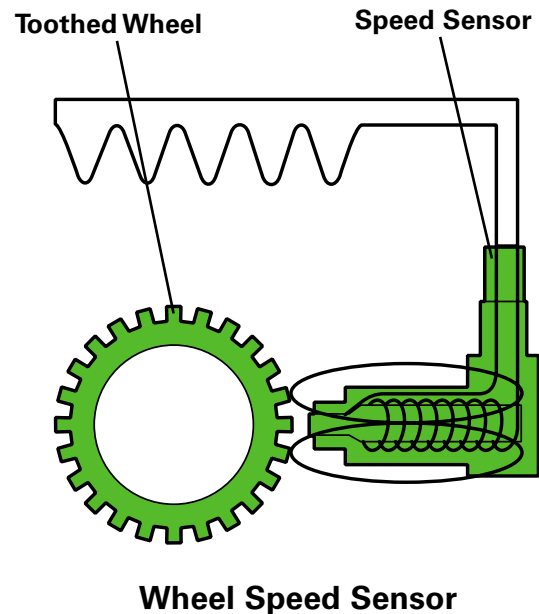

Longitudinal Acceleration Sensor G249

The longitudinal acceleration sensor G249 is attached to the right side A pillar.

On vehicles that are driven at one axle only, the system calculates the vehicle's longitudinal acceleration from the data supplied by the Sensor -2- for Brake Pressure G214, the signals supplied by the ABS wheel speed sensors and information from the engine management system.

On four-wheel drive vehicles with the Haldex coupling, the front and rear wheels are connected when the coupling is closed. The calculated true vehicle road speed, which is determined from the individual wheel speeds, may be too inaccurate under certain conditions at low coefficients of friction and when the Haldex coupling is closed. The longitudinal acceleration measured is used to verify calculated road speed.

Effects of signal failure

Without the additional measurement of longitudinal acceleration, it is not possible to determine the true vehicle road speed exactly in unfavorable conditions. As a result, the electronic stability program (ESP) and anti-slip regulation system (ASR) will not operate.

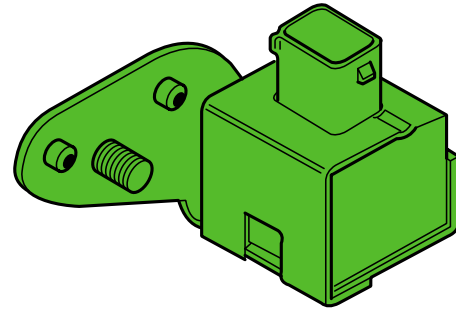

Longitudinal Acceleration Sensor

Electrical circuit

The longitudinal acceleration sensor is connected to the control unit J104 via three lines.

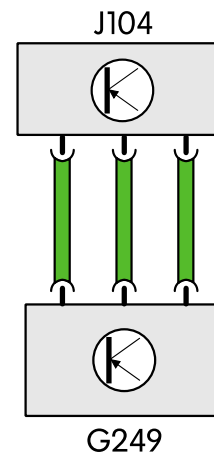

Haldex Coupling

Brake Light Switch F

Brake light switch F is located at the upper end of the brake pedal and is secured to the pedal support.

Signal utilization

The brake light switch sends the "brake activated" signal to ABS control module J104. The control unit informs the Haldex control module along the CAN bus.

When the brake is applied, the Haldex control module immediately opens the pressure regulator via the positioning motor and the Haldex coupling clutch is opened.

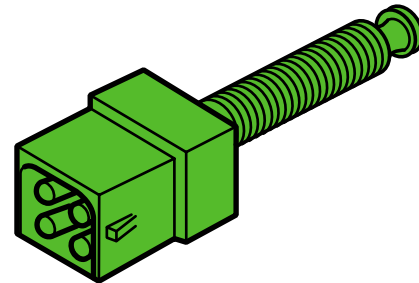

Brake Light Switch

Effect of signal failure

The information provided by the CAN bus is used as an alternative.

Electrical circuit

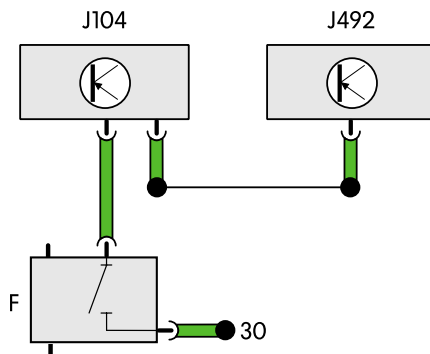

Handbrake Switch F9

Handbrake switch F9 is located under the hand brake lever.

Signal utilization

The handbrake switch sends the "handbrake engaged" signal to the ABS control module J104 and simultaneously to the Haldex control module J492.

Whereas the ABS control module transfers this information to the Haldex control unit in "filtered" form along the CAN bus, the Haldex control module also receives the information directly from the handbrake switch.

If the signal generated by handbrake switch F9 is picked up, the Haldex coupling clutch is opened.

Electrical circuit

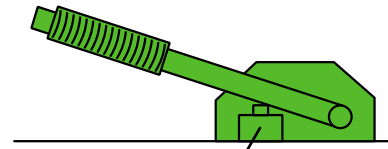
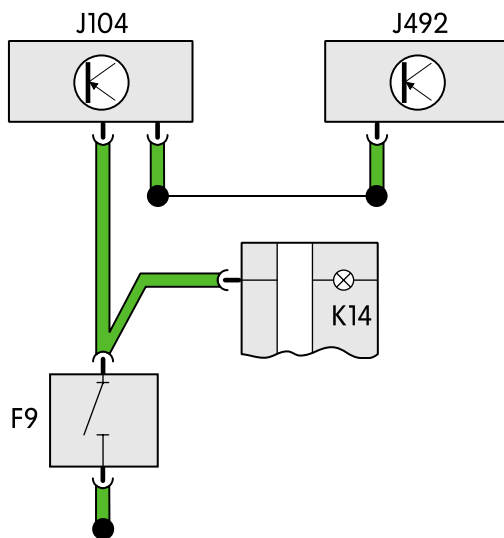

Handbrake Switch F9

Effects of signal failure

If the switch remains closed, then no all-wheel drive control is available and restrictions are placed on ABS control.

Haldex Coupling

Haldex Coupling Temperature Sensor G271

The Haldex coupling temperature sensor is installed near the regulating valve in the Haldex control module housing and is immersed in hydraulic fluid.

Signal utilization

The temperature sensor senses the momentary hydraulic oil temperature and sends this information to the Haldex control module. This information is used for adapting to the changing viscosity of the hydraulic fluid.

If the hydraulic fluid temperature exceeds 100°C, the clutch is released. If the temperature of the hydraulic fluid drops below 100°C, the clutch is again pressurized.

Effects of signal failure

All-wheel drive is shut off if no signal is received from the temperature sensor G271.

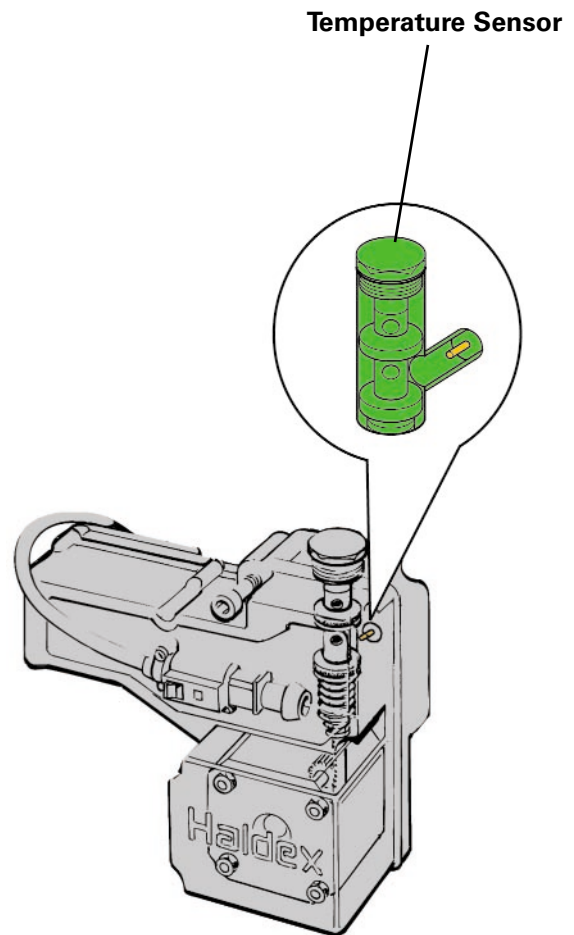

Temperature	Hydraulic Fluid/Viscosity	Regulating Valve
In the minus range	High viscosity	Slightly more open
Normally 20° C	Normal	Normally open
Over 20° C	Low viscosity	Slightly less open

Haldex Control Module J492

The Haldex control module is mounted directly on the housing of the Haldex coupling and combines with the positioning motor and the regulating valve to form a unit.

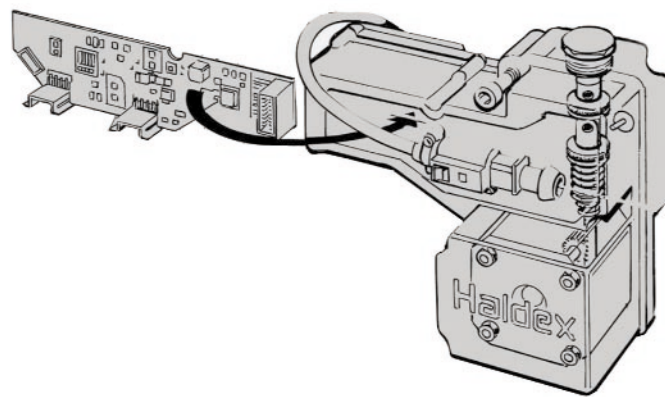

Haldex Control Module J492

Design and function

The Haldex coupling control module is connected to the engine and the ABS control unit via the CAN bus. From the signals that are generated by the Motronic ECM sensors, the Haldex control module decides what oil pressure to apply to the plates of the Haldex coupling clutch.

The oil pressure acting on the plates of the Haldex coupling clutch determine what torque is to be transmitted to the rear axle.

Effects of signal failure

If the Haldex control module is not operating correctly, no all-wheel drive is possible.

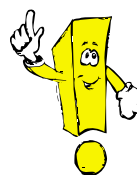

The address word to access the Haldex Control Module is 22.

Haldex Coupling

Positioning Motor V184

The positioning motor is integrated in the Haldex control module housing.

Design and function

The positioning motor is supplied with voltage by the Haldex control module and functions as a stepping motor.

At the command of the Haldex control module, the positioning motor changes the level of the regulating pin in the pressure regulator via a small pinion gear.

The level of the regulating pin changes the cross section of a return bore in the pressure regulator. This controls the pressure acting on the working piston, and in turn, on the clutch plates.

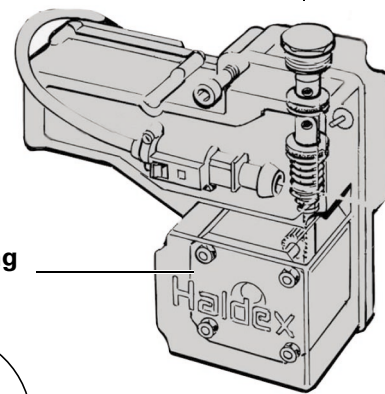
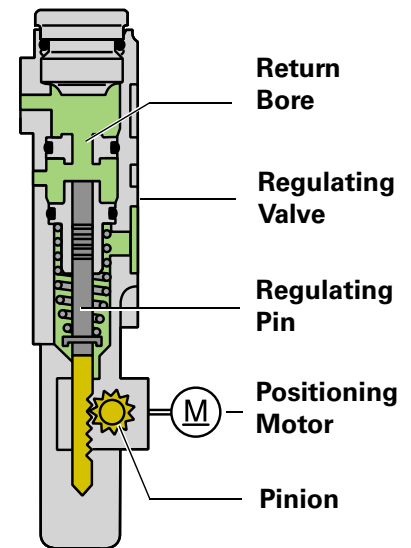

Positioning Motor

Regulator Closed:

Maximum pressure on clutch plates.

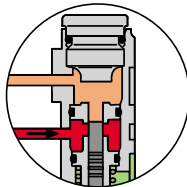

Regulator Partially Open:

Reduced pressure on clutch plates.

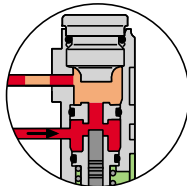

Regulator Fully Open:

No pressure on clutch plates.

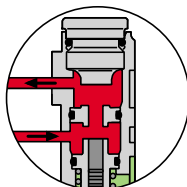

Haldex Coupling

Haldex Clutch Pump V181

The pump for the Haldex coupling is attached to the Haldex coupling housing.

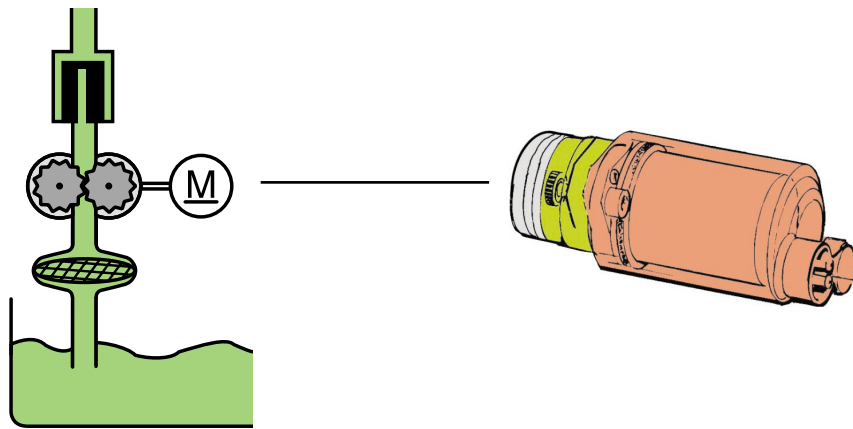

Haldex Clutch Pump

Design

After the engine has been started, the pump for the Haldex coupling is supplied with voltage by the Haldex control module as soon as the engine speed exceeds 400 rpm.

Electrical circuit

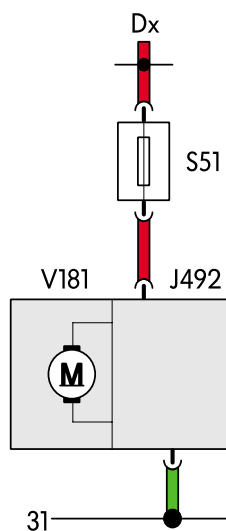

Function

The pump for the Haldex clutch conveys oil to the lifting piston and brings the lifting piston into contact with the lifting plate via roller bearings.

At the same time, oil reaches the working piston. This eliminates any play from the clutch plate set and ensures quick clutch response.

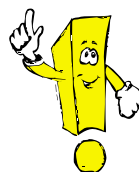

Effects of signal failure

No all-wheel drive.







The Haldex clutch pump is directly supplied with voltage by the Haldex control module.

Haldex Coupling

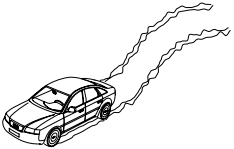
	 Parking	 Acceleration	 High-speed Driving
Difference in speed between front and rear axles	Low	High	Low
Torque required at the rear axle	Low	High	Low
Condition of multi-plate clutch	Low contact pressure	High contact pressure, up to maximum. EDL control system can increase contact pressure.	Closed, as required
Input Signals	<ul style="list-style-type: none"> • Engine torque • Engine speed • Accelerator pedal position • Four wheel sensors 	<ul style="list-style-type: none"> • Engine torque • Engine speed • Accelerator pedal position • Four wheel sensors 	<ul style="list-style-type: none"> • Engine torque • Engine speed • Accelerator pedal position • Four wheel sensors

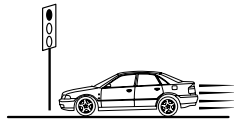
Haldex Coupling

 Slippery Surfaces	 Emergency wheel installed	 Braking	 Towing
Fluctuates between low and high	Normal to high	Normal to high	High
Fluctuates between low and high	Low	0	0
Closed, up to maximum	Open or slightly closed	Open	Open, electrical pre-pressure pump is off when ignition is off
<ul style="list-style-type: none"> • Engine torque • Engine speed • Accelerator pedal position • Four wheel sensors • CAN-bus communication 	<ul style="list-style-type: none"> • Four wheel sensors • via ABS control unit 	<ul style="list-style-type: none"> • Four wheel sensors • via ABS control unit • Brake light switch 	<ul style="list-style-type: none"> • Engine speed less than 400 rpm

Haldex Coupling

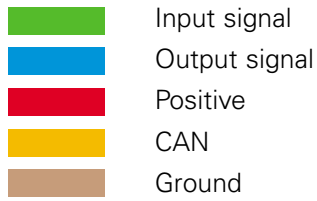

Components

- D Ignition switch
- F Brake light switch
- F9 Hand brake warning switch
- G271 Hydraulic temperature sensor
- J220 Motronic engine control module
- J104 ABS control module with EDL/TCS/ESP in the engine compartment at the left
- J285 Control module with display unit in the dash panel insert
- J492 Control module for four-wheel drive (located near the rear axle differential)
- K Connection (K-wire (diagnosis))
- K14 Handbrake warning lamp
- M21 Bulb for left rear brake
- S51 Fuse
- V181 Haldex clutch pump
- V184 Positioning motor for oil pressure
- A80 Connection -1- (x) in dash panel wiring harness
- A121 Connection (Hi bus)
- A122 Connection (Low bus)

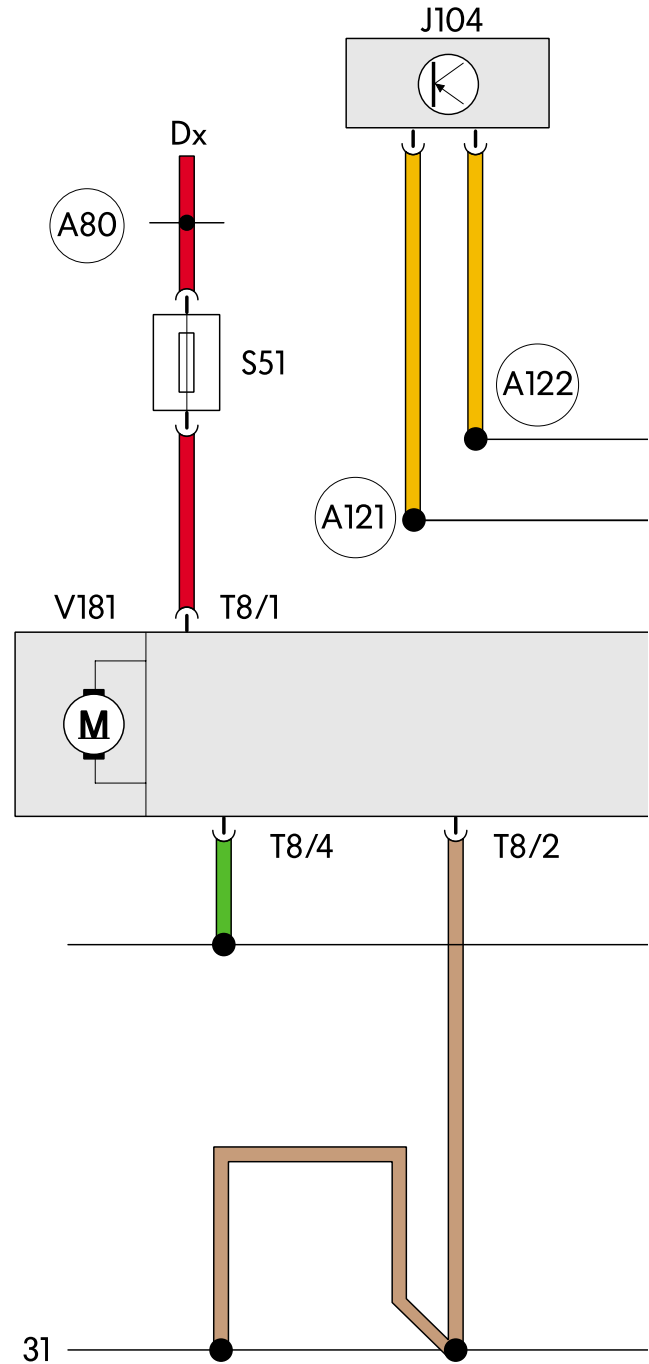

Haldex Coupling

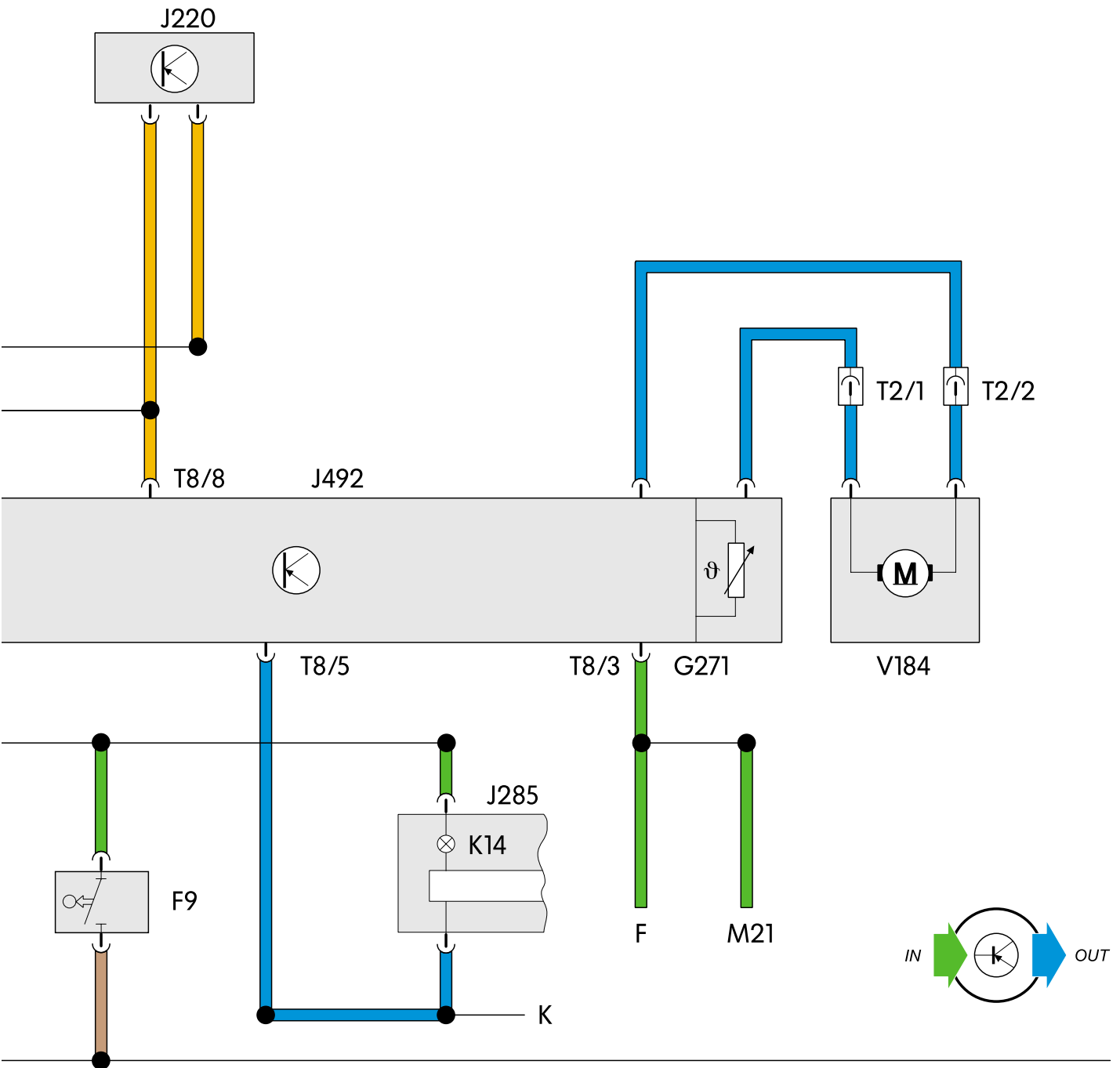

Haldex Coupling

Self-diagnosis

The self-diagnosis electrically monitors:

- the signals generated by the sensors
- activation of the positioning motors
- the control unit by carrying out a self-test

If the control unit detects a fault, it calculates a substitute value from other signals and makes an emergency running program available.

In the data transfer facility, the following functions can be read out under the address word 22 "4-wheel-drive electronics" with the VAS 5051 testing and information system:

02 Check DTC Memory

03 Output Diagnostic Test Mode (DTM)

05 Erase DTC Memory

06 End Output

08 Read Measuring Value Block

For more detailed information, please refer to AESIS.

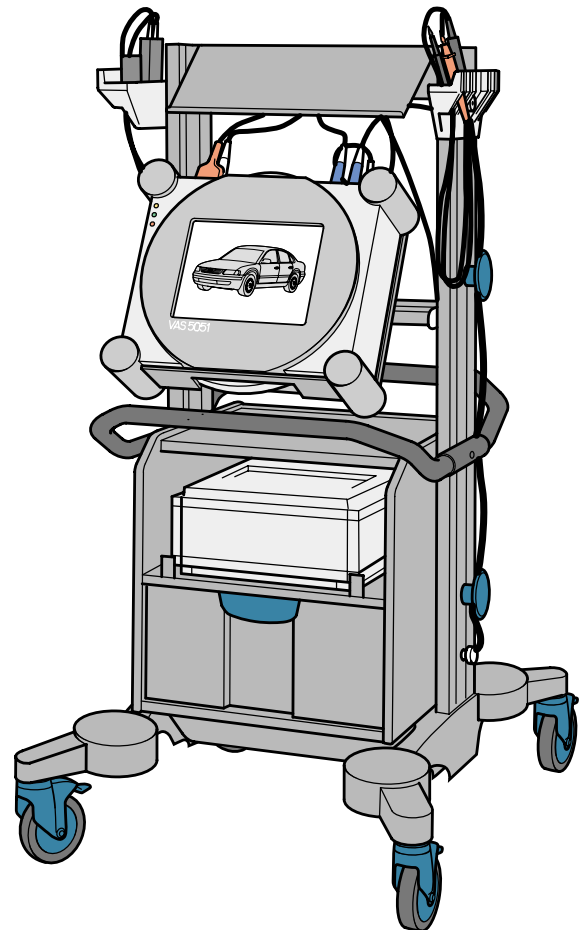

VAS 5051 Scan Tool