

# **REPAIR-MANUAL**

## **5 HP - 19**

**ZF GETRIEBE GMBH SAARBRÜCKEN**

Version 99/04/15

Subject to alterations

© Copyright 1998, all rights reserved. Published by  
ZF Getriebe GmbH, Saarbrücken, Department MKTD

No part of this manual may be reproduced or transmitted in any form  
or by any means, electronic or mechanical, including photocopying and recording,  
for any purpose without the express written permission of  
**ZF Getriebe GmbH, Saarbrücken**

Printed in Germany

# Contents

	<b>Page</b>
<b>Preliminary information</b>	<b>ii</b>
<b>1. General information</b>	<b>1.1/1</b>
1.1 Picture of the transmission	1.1/1
1.2 Power flow diagram	1.2/1
1.3 Specifications	1.3/1
1.3.1 Screw torque specifications	1.3/1
1.3.1.1 Pump	1.3/1
1.3.1.2 Cylinder DG	1.3/1
1.4 Making adjustments	1.4/1
1.4.0 Preparing the clearance measurement tool	1.4/1
1.4.1 Adjusting clearance of brake F (snap ring)	1.4/3
1.4.2 Adjusting clearance of brake D (snap ring)	1.4/5
1.4.3 Adjusting clearance of brake G (snap ring)	1.4/7
1.4.4 Adjusting clearance of brake E (snap ring)	1.4/9
1.4.5 Adjusting clearance of clutch A (snap ring)	1.4/11
1.4.6 Adjusting clearance of clutch B (snap ring)	1.4/13
1.4.7 Adjusting clearance of brake C (snap ring)	1.4/15
1.4.8 Output play (shim)	1.4/17
1.4.9 Input play (shim)	1.4/19
1.4.10 Adjusting the switch (detent spring)	1.4/21
1.5 Tightening torques	1.5/1
1.6 Transmission test (test bench/vehicle)	1.6/1
1.7 Special tools	1.7/1
<b>2. Removing assemblies</b>	<b>2.1/1</b>
2.1 Removing the converter, oil pan and automatic control unit	2.1/1
2.2 Removing the oil supply	2.2/1
2.3 Removing the input assembly	2.3/1
2.4 Removing the tower	2.4/1
2.5 Removing the output assembly	2.5/1
<b>Disassembly</b>	
2.6 Output assembly	2.6/1
2.7 Tower	2.7/1
2.7.1 Planetary drive	2.7/1
2.7.2 Clutch F	2.7/4
2.7.3 Brake D/G	2.7/5
2.8 Input assembly	2.8/1
2.8.1 Clutch E	2.8/2
2.8.2 Clutch A	2.8/3
2.8.3 Clutch B	2.8/4
2.9 Oil supply with brake C	2.9/1
2.9.1 Brake C	2.9/1
2.9.2 Pump	2.9/2

<b>3.</b>	<b>Assembly</b>	<b>3.1/1</b>
3.1	Housing with selector mechanism and parking lock	3.1/1
3.2	Tower	3.2/1
	3.2.1 Planetary drive	3.2/1
	3.2.2 Clutch F	3.2/4
	3.2.3 Brake DG with freewheel, 1st gear	3.2/6
3.3	Output assembly	3.3/1
3.4	Planetary drives I and II	3.4/1
3.5	Input assembly (with clutches A and B)	3.5/1
	3.5.1 Clutch E (input)	3.5/1
	3.5.2 Clutch A (input)	3.5/4
	3.5.3 Clutch B (input)	3.5/7
3.6	Oil supply with brake C	3.6/1
3.7	Input assembly with oil supply	3.7/1
3.8	Automatic control unit, flow control valve, oil filter and oil pan	3.8/1
3.9	Position switch and converter	3.9/1



# Preliminary information

This manual covers the procedure for repairing the complete transmission.

Repairs to this transmission must be carried out by persons trained by ZF Getriebe GmbH.

All disassembly and re-assembly work should be carried out in the order described.

The photographs apply to various versions and have therefore been kept general. They are not binding in every case.

Important changes that are specific to particular applications and need to be taken into account when carrying out repair work are announced in *Service Bulletins* and training courses.

If this repair manual is given to a third party, it will not be covered by our alteration service.

The instructions and specifications given in the *Service Bulletins* must be followed when carrying out repairs.

Depending on the damage that has occurred, it may be possible to limit repair work to this damage.

The following points should be noted:

- Seals, e.g. O-rings, shaft seals, gaskets and filters, should always be renewed.
- All O-rings, rectangular-section rings and other sealing rings should be smeared with white petroleum jelly before being fitted.
- All bearings must be fitted in a lightly oiled condition.
- All lined clutch discs and steel discs on high-mileage transmissions (> 80,000 km) must be replaced.
- Following damage to clutches/brakes, the converter, oil tubes and oil cooler must be thoroughly and adequately cleaned with a suitable cleaning agent.

Before carrying out repair work, make sure that:

- All special tools required are readily available.  
The complete set of special tools is listed in Chapter 1.8.
- A suitable transmission test bench is available.  
See *Service Bulletins* for the required test values.

**Please note:**

In this manual, the automatic control unit is treated as a complete unit. It should not be disassembled except by a specialist. It should be exchanged as a complete unit.

A separate manual is planned for the automatic control unit.

**Important:**

The transmission is filled with a long-life oil.

**The oil does not have to be changed until it has been in use for 10 years.**

The transmission must be delivered with the volume and type of oil specified in the relevant parts list documentation (see ELCAT).

Otherwise, the transmission may fail.

Techn. After Sales Service

Techn. Documentation

After Sales Service School

Bach

Reus

Schultz

**1. General information**

**1.1 Picture of the transmission**

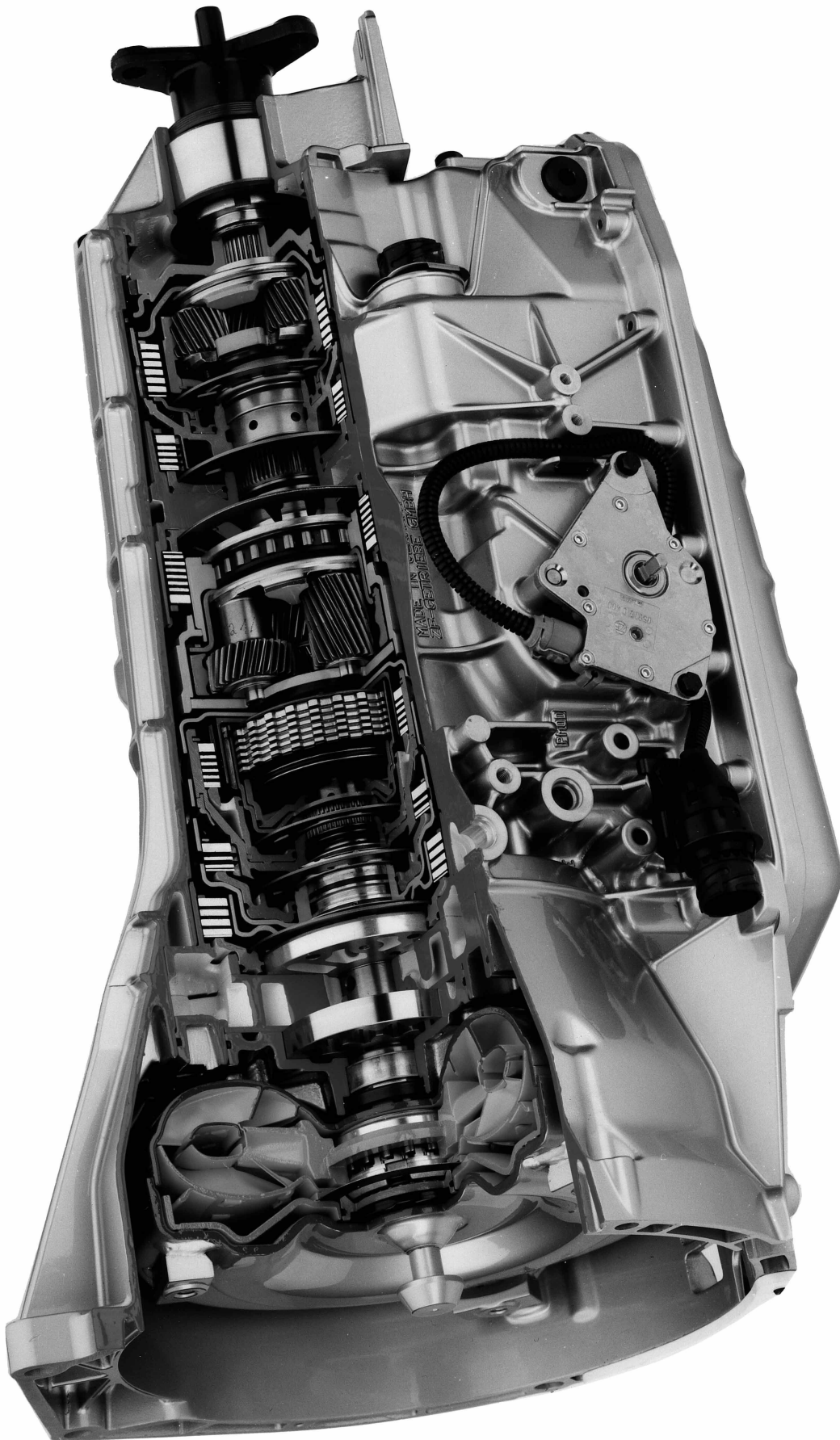



## 1.2 Power flow diagram

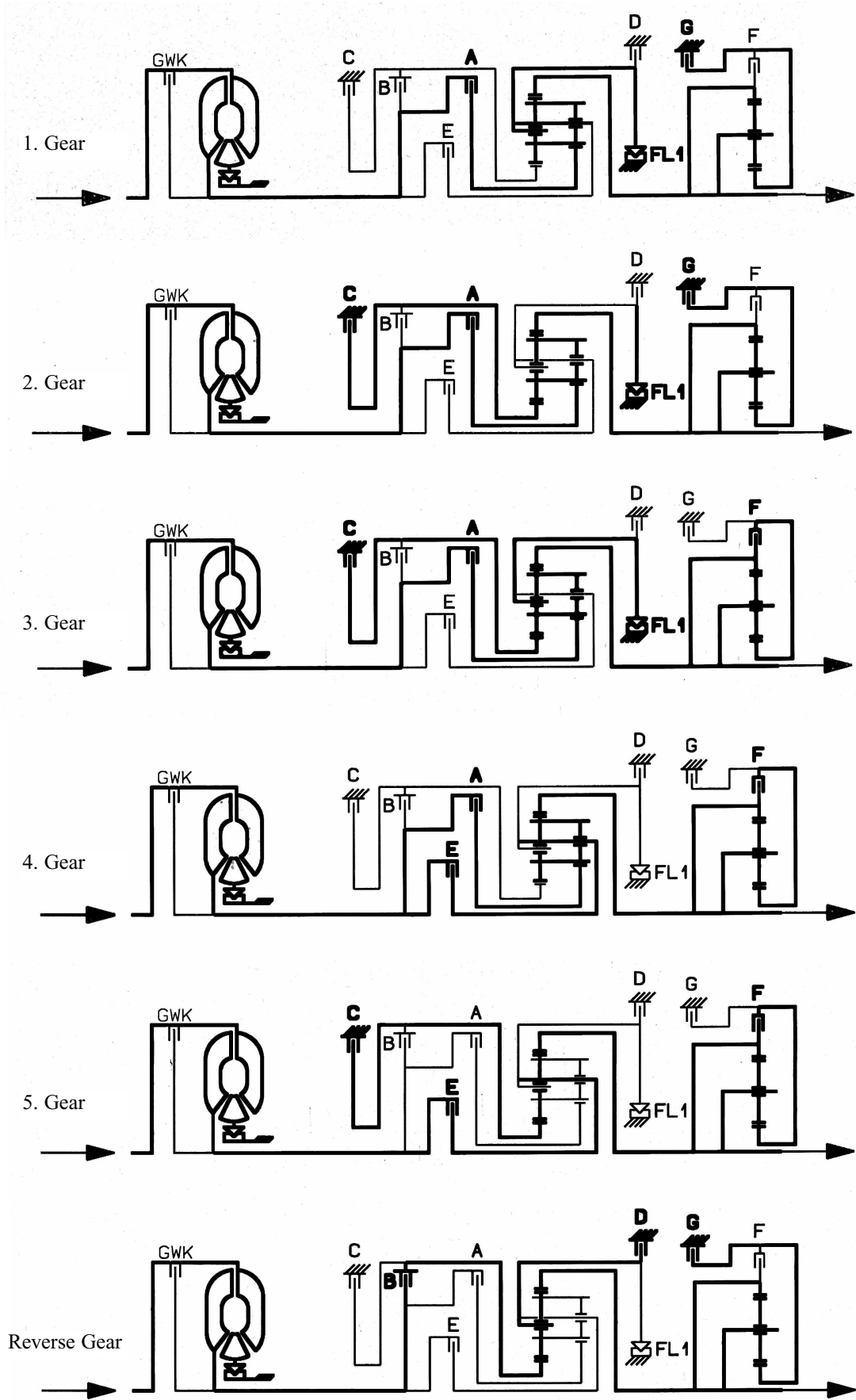



### 1.3 Specifications

#### 1.3.1 Screw torque specifications

##### 1.3.1.1 Pump

According to **specification 1056 700 300** screw the pump in the following order:  
(see diagram)

1 ⇨ 2 ⇨ 3 ⇨ ... ⇨ 15

#### Attention!

Tighten screw **1** with 6 Nm, all others with 10 Nm!

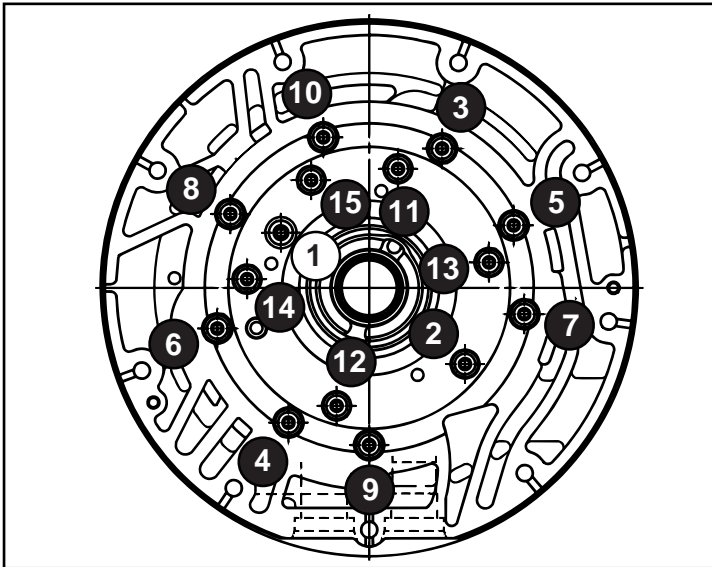

##### 1.3.1.2 Cylinder DG

Screw in 3 machine screws 73.200 by about 2 turns.

Initially, tighten the central screw at 30 Nm and the two outer ones at 15 Nm.

Now tighten the central screw at 63 Nm and the two outer ones at 30 Nm.

Finally, tighten the two outer screws at 63 Nm.

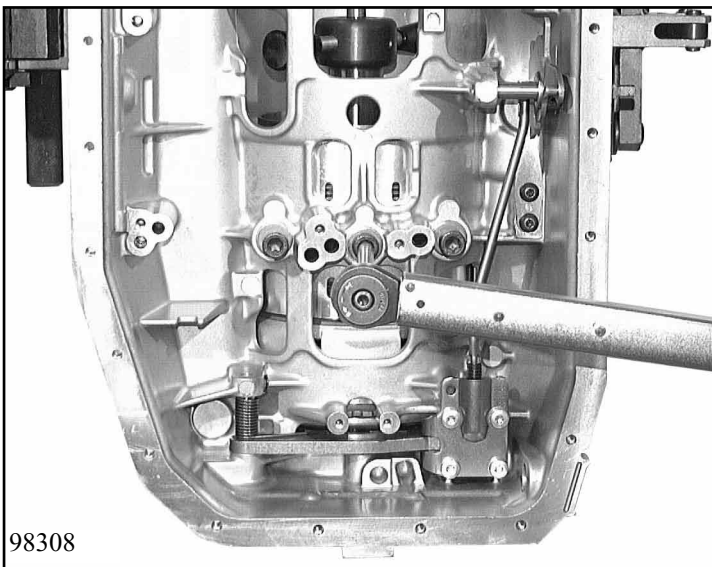





## 1.4 Making adjustments

### 1.4.0 Measuring the clutch pack (procedure)

Place the two intermediate pieces 5p01 000 329 at the marked positions on measuring fixture 5p01 000 330.



Use knurled screw to turn adjusting device 5p01 001 458 to upper limit position.  
Attach force-measuring unit 5p01 000 329 to adjusting device 5p01 001 458.



Fasten adjusting device with 4 knurled screws to the measuring fixture using the intermediate pieces.  
Connect measuring plate 5p01 040 330 to force-measuring unit using fixing pin.

Use knurled screw to clamp the clutch pack to be measured (with corrugated steel clutch disc – if present – at the bottom) in device at 200 N.

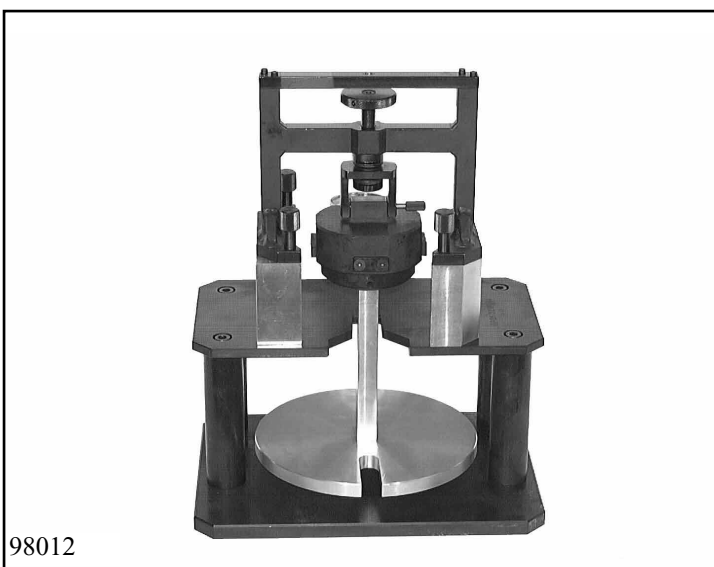

Check the value on the force-measuring unit.

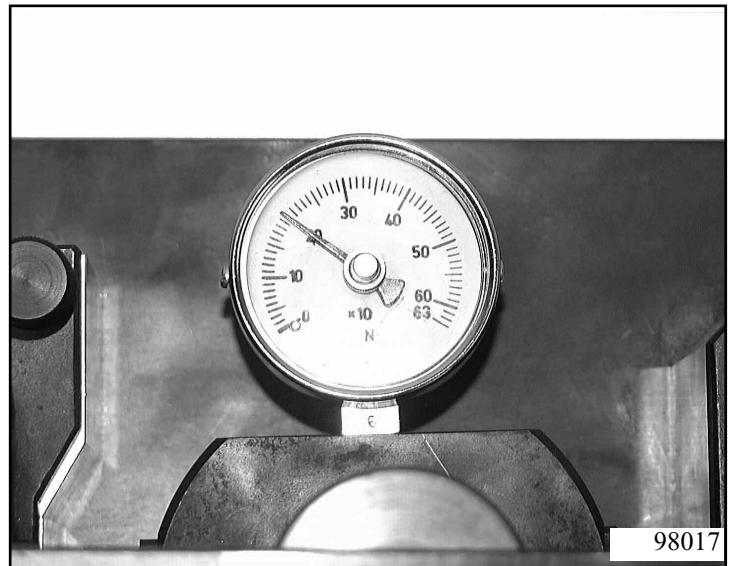

Then put measuring bar 5p01 060 330 on the measuring plate, insert the measuring base of the dial gauge into the groove of the measuring plate on the top disc of the pack and set the dial gauge to zero.

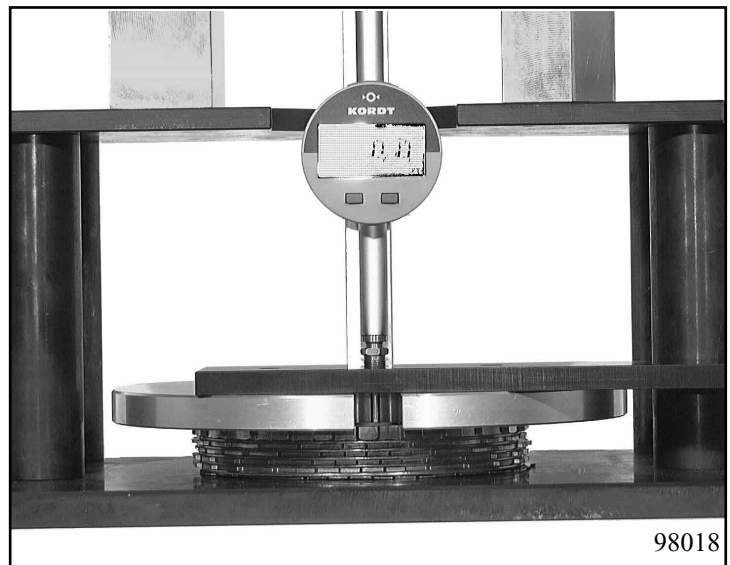

Now measure down to the base plate using the measuring bar.

Read off the measurement value  $\Rightarrow M_X$

**Note!**

In each case, index **X** in  $M_X$  stands for the disc pack that was put in for the clutches/brakes (A, B, C, D, E, F, G)

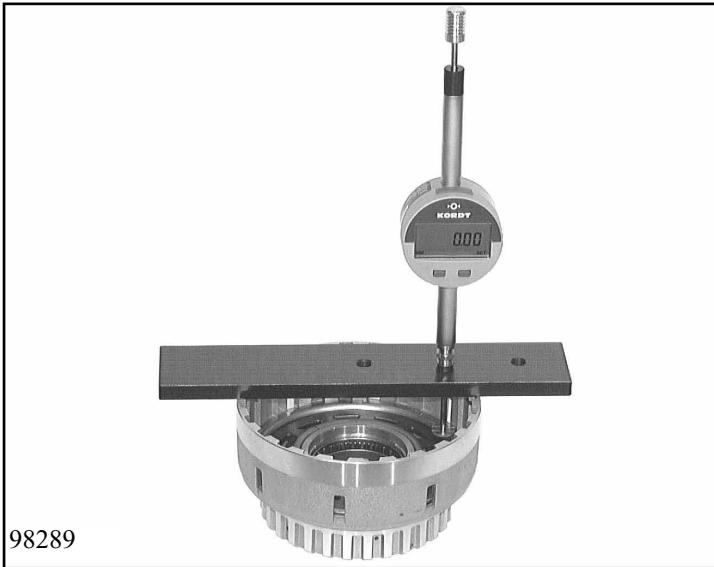

98289

### 1.4.1 Adjusting clearance of brake F (snap ring)

Determine installation space  $E_F$  for brake F with measuring bar 5p01 000 330. To do this, put measuring bar 5p01 000 330 onto the edge of the cylinder for brake F. Put the measuring base on the highest point of the disc supporting surface on the piston and set the dial gauge to "0". Pull the measuring sensor upwards, guide it into the snap-ring groove and press it there against the groove's upper edge. Repeat measurement twice, turning by  $120^\circ$ . Average measurement values  $F_1, F_2, F_3 \Rightarrow W_F$

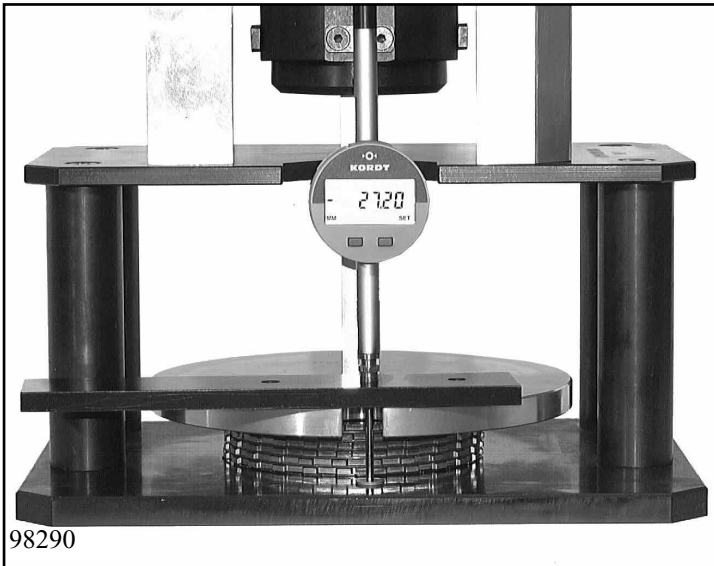

98290

Determine thickness  $M_F$  of the brake F disc pack according to **Chapter 1.4.0: Measuring the disc pack.**

$\Rightarrow M_F$

Installation space  $E_F$  is equal to  $W_F$  plus the thickness of the base F.  $\Rightarrow E_F$

Test value  $P_F$  is equal to installation space  $E_F$  minus  $M_F$

The  $P_F$  value must lie between 3.46 - 5.19 mm  
**Test specification 1060 700 062**  
 Version B

Use test value  $P_F$  to select snap ring  $S_F$ .

#### Calculation:

$$E_F = W_F + F$$

$$P_F = E_F - M_F$$

Clutch clearance  $L_F$  should be 2.26 - 2.55 mm with 5 lined clutch discs.

**Example (for 1.4.1):**

$$\mathbf{F} = 1.48 \text{ mm (Fußdicke)}$$

$$\mathbf{F_1} = 29.74 \text{ mm}$$

$$\mathbf{F_2} = 29.77 \text{ mm}$$

$$\mathbf{F_3} = 29.77 \text{ mm}$$

$$\begin{aligned} \mathbf{W_F} &= (29.74 + 29.77 + 29.77)/3 \\ &= 29.76 \text{ mm} \end{aligned}$$

$$\mathbf{M_F} = 27.2 \text{ mm}$$

$$\begin{aligned} \mathbf{E_F} &= 29.76 + 1.48 \\ &= 31.24 \text{ mm} \end{aligned}$$

$$\begin{aligned} \mathbf{P_F} &= 31.24 - 27.2 \\ &= 4.04 \text{ mm} \end{aligned}$$

$$\mathbf{S_F} = 1.6 \text{ mm}$$

$$\mathbf{L_F} = 4.04 - 1.6$$

$$\Rightarrow \mathbf{L_F} = 2.44 \text{ mm}$$



98294

### 1.4.2 Adjusting clearance of brake D (snap ring)

Determine installation space  $E_D$  for brake D with measuring bar 5p01 000 330. To do this, put measuring bar 5p01 000 330 onto the edge of the cylinder for brake D. Put the measuring base on the highest point of the disc supporting surface on the piston and set the dial gauge to "0". Pull the measuring sensor upwards, guide it into the snap-ring groove and press it there against the groove's upper edge. Repeat measurement twice, turning by  $120^\circ$ .

Average measurement values  $D_1, D_2, D_3 \Rightarrow W_D$

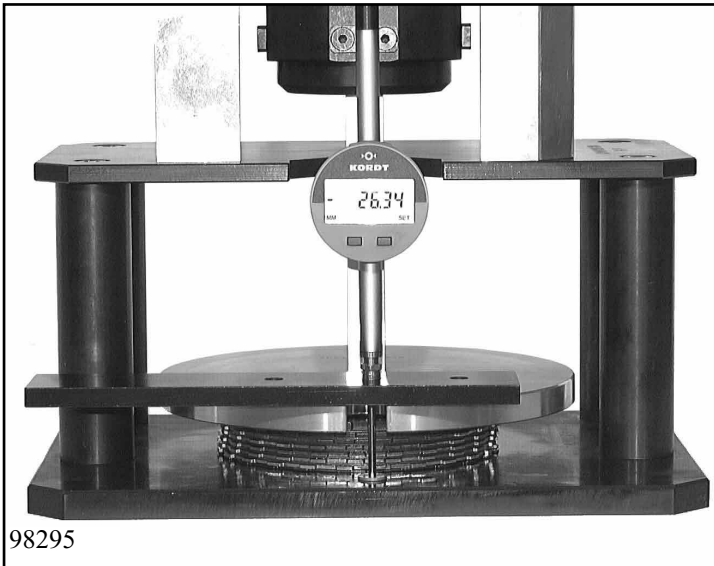

98295

Determine thickness  $M_D$  of the brake D disc pack according to **Chapter 1.4.0: Measuring the disc pack.**

$\Rightarrow M_D$

Installation space  $E_D$  is equal to  $W_F$  plus the thickness of the base  $F$ .  $\Rightarrow E_D$

Test value  $P_D$  is equal to installation space  $E_D$  minus  $M_D$ .

The  $P_D$  value must lie between 4.65 - 6.45 mm  
**Test specification 1060 700 265 -**  
 Version A

Use test value  $P_D$  to select snap ring  $S_D$ .

#### Calculation:

$$E_D = W_D + F$$

$$P_D = E_D - M_D$$

Clutch clearance  $L_D$  should be 2.29 - 2.59 mm with 6 lined clutch discs.

**Example (for 1.4.2):**

$$F = 1.48 \text{ mm (base thickness)}$$

$$D_1 = 30.21 \text{ mm}$$

$$D_2 = 30.22 \text{ mm}$$

$$D_3 = 30.26 \text{ mm}$$

$$W_D = (30.21 + 30.22 + 30.26)/3 \\ = 30.23 \text{ mm}$$

$$M_D = 26.34 \text{ mm}$$

$$E_D = 30.23 + 1.48$$

$$= 31.71 \text{ mm}$$

$$P_D = 31.71 - 26.34$$

$$= 5.37 \text{ mm}$$

$$S_D = 3.0 \text{ mm}$$

$$L_D = 5.37 - 3.0$$

$$\Rightarrow L_D = 2.37 \text{ mm}$$

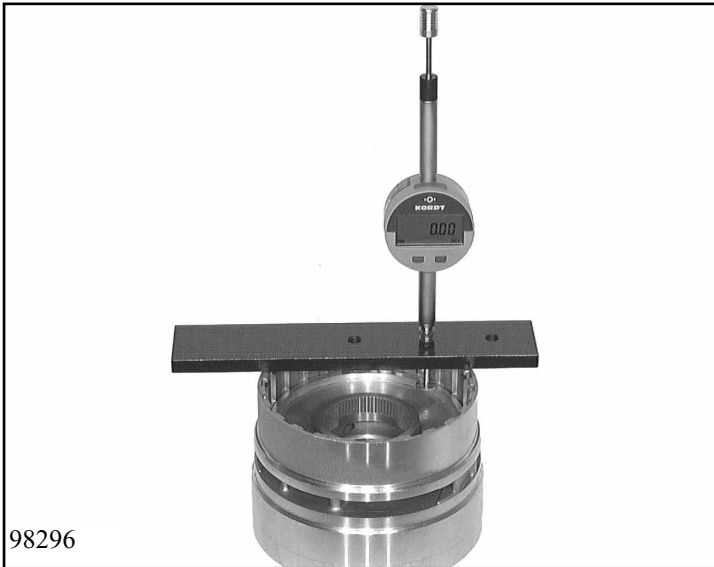

98296

### 1.4.3 Adjusting clearance of brake G (snap ring)

Determine installation space  $E_G$  for brake G with measuring bar 5p01 000 330. To do this, put measuring bar 5p01 000 330 onto the edge of the cylinder for brake G. Put the measuring base on the highest point of the disc supporting surface on the piston and set the dial gauge to "0". Pull the measuring sensor upwards, guide it into the snap-ring groove and press it there against the groove's upper edge. Repeat measurement twice, turning by  $120^\circ$ .

Average measurement values  $G_1, G_2, G_3 \Rightarrow W_G$

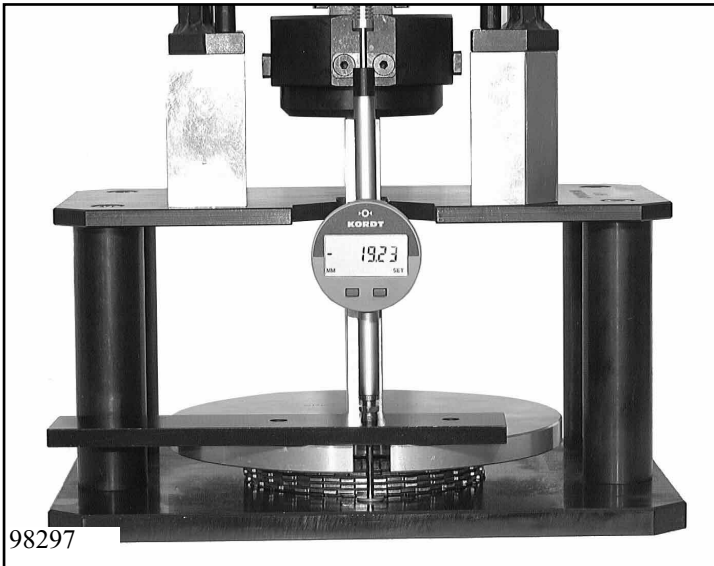

98297

Determine thickness  $M_E$  of the brake E disc pack according to **Chapter 1.4.0: Measuring the disc pack.**

$\Rightarrow M_G$

Installation space  $E_G$  is equal to  $W_G$  plus the thickness of the base  $F \Rightarrow E_G$

Test value  $P_G$  is equal to installation space  $E_G$  minus  $M_G$ .

The  $P_E$  value must lie between 3.78 - 5.17 mm

**Test specification 1060 700 063**

Version A.

Use test value  $P_G$  to select snap ring  $S_G$ .

**Calculation:**

$$E_G = W_G + F$$

$$P_G = E_G - M_G$$

Clutch clearance  $L_G$  should be 1.79 - 2.08 mm with 4 lined clutch discs.

**Example (for 1.4.3):**

$$F = 1.48 \text{ mm (base thickness)}$$

$$G_1 = 21.98 \text{ mm}$$

$$G_2 = 22 \text{ mm}$$

$$G_3 = 21.99 \text{ mm}$$

$$W_G = (21.98 + 22 + 21.99)/3 \\ = 21.99 \text{ mm}$$

$$M_G = 19.23 \text{ mm}$$

$$E_G = 21.99 + 1.48 \\ = 23.47 \text{ mm}$$

$$P_G = 23.47 - 19.23 \\ = 4.24 \text{ mm}$$

$$S_G = 2.4 \text{ mm}$$

$$L_G = 4.24 - 2.4$$

$$\Rightarrow L_G = 1.84 \text{ mm}$$



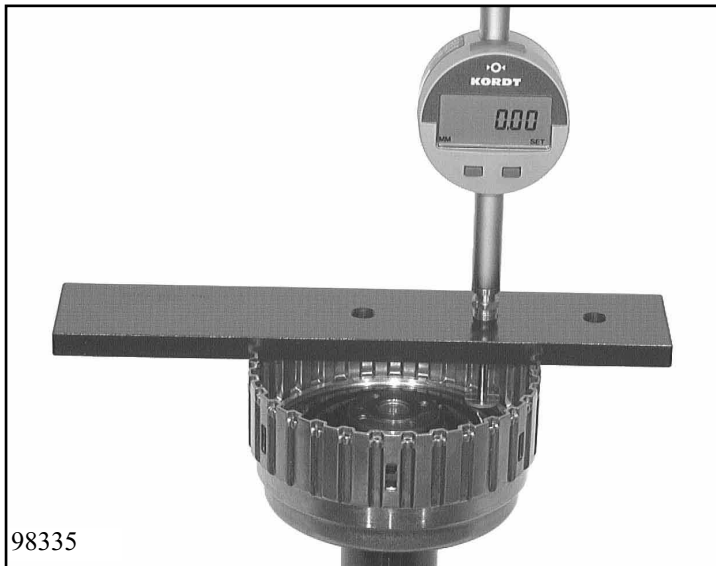

98335

#### 1.4.4 Adjusting clearance of brake E (snap ring)

Determine installation space  $E_E$  for brake E with measuring bar 5p01 000 330. To do this, put measuring bar 5p01 000 330 onto the edge of the cylinder for brake E. Put the measuring base on the highest point of the disc supporting surface on the piston and set the dial gauge to "0". Pull the measuring sensor upwards, guide it into the snap-ring groove and press it there against the groove's upper edge. Repeat measurement twice, turning by  $120^\circ$ .

Average measurement values  $E_1, E_2, E_3 \Rightarrow W_E$



98336

Determine thickness  $M_E$  of the brake E disc pack according to  
**Chapter 1.4.0: Measuring the disc pack.**

$\Rightarrow M_E$

Installation space  $E_E$  is equal to  $W_E$  plus the thickness of the base  $F$ .  $\Rightarrow E_E$

Test value  $P_E$  is equal to installation space  $E_E$  minus  $M_E$ .

The  $P_E$  value must lie between 3.04 - 4.46 mm

**Test specification 1056 700 309**

Version A

Use test value  $P_E$  to select snap ring  $S_E$ .

**Calculation:**

$$E_E = W_E + F$$

$$P_E = E_E - M_E$$

Clutch clearance  $L_E$  should be 1.78 - 2.08 mm with 5 lined clutch discs.

**Example (for 1.4.4):**

$$F = 1.48 \text{ mm (base thickness)}$$

$$E_1 = 23.22 \text{ mm}$$

$$E_2 = 23.23 \text{ mm}$$

$$E_3 = 23.27 \text{ mm}$$

$$W_E = (23.22 + 23.23 + 23.27)/3 \\ = 23.24 \text{ mm}$$

$$M_E = 21.64 \text{ mm}$$

$$E_E = 23.24 + 1.48 \\ = 24.72 \text{ mm}$$

$$P_E = 24.72 - 21.64 \\ = 3.08 \text{ mm}$$

$$S_E = 1.2 \text{ mm}$$

$$L_E = 3.08 - 1.2$$

$$\Rightarrow L_E = 1.88 \text{ mm}$$



### 1.4.5 Adjusting clearance of clutch A (snap ring)

Determine installation space  $E_A$  for clutch A with measuring bar 5p01 000 330. To do this, put measuring bar 5p01 000 330 onto the edge of the cylinder for clutch A. Put the measuring base on the highest point of the disc supporting surface on the piston and set the dial gauge to "0". Pull the measuring sensor upwards, guide it into the snap-ring groove and press it there against the groove's upper edge. Repeat measurement twice, turning by  $120^\circ$ .

Average measurement values  $A_1, A_2, A_3 \Rightarrow W_A$

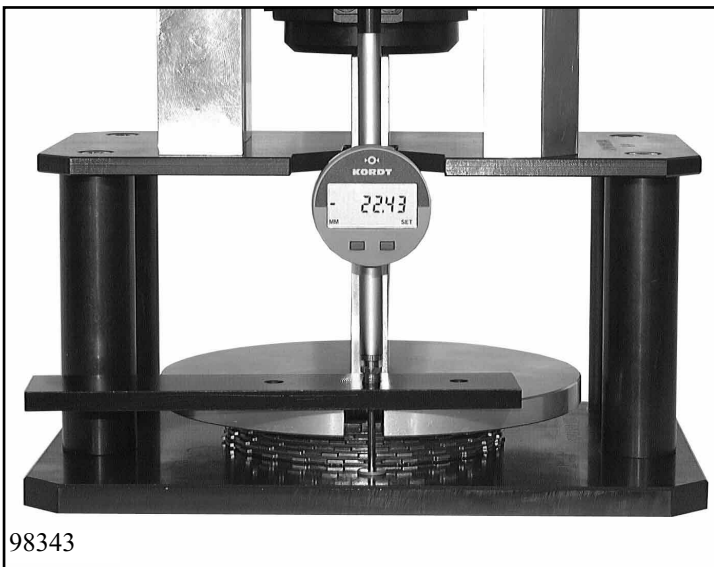

Determine thickness  $M_A$  of the clutch A disc pack according to **Chapter 1.4.0: Measuring the disc pack.**

$\Rightarrow M_A$

Installation space  $E_A$  is equal to  $W_A$  plus the thickness of the base  $F$ .  $\Rightarrow E_A$

Test value  $P_A$  is equal to installation space  $E_A$  minus  $M_A$ .

Value  $P_A$  should be between 3.09 - 4.58 mm

**Test specification 1060 700 061**

Version A

Use test value  $P_A$  to select snap ring  $S_A$ .

#### Calculation:

$$E_A = W_A + F$$

$$P_A = E_A - M_A$$

Clutch clearance  $L_A$  should be 2.06 - 2.35 mm with 5 lined clutch discs.

**Example (for 1.4.5):**

$$F = 1.48 \text{ mm (base thickness)}$$

$$A_1 = 24.82 \text{ mm}$$

$$A_2 = 24.84 \text{ mm}$$

$$A_3 = 24.86 \text{ mm}$$

$$W_D = (24.82 + 24.84 + 24.86)/3$$

$$W_A = 24.84 \text{ mm}$$

$$M_A = 22.43 \text{ mm}$$

$$E_A = 24.84 + 1.48$$

$$= 26.32 \text{ mm}$$

$$P_A = 26.32 - 22.43$$

$$= 3.91 \text{ mm}$$

$$S_A = 1.8 \text{ mm}$$

$$L_A = 3.91 - 1.8$$

$$\Rightarrow L_A = 2.11 \text{ mm}$$



#### 1.4.6 Adjusting clearance of clutch B (snap ring)

Determine installation space  $E_B$  for clutch B with measuring bar 5p01 000 330. To do this, put measuring bar 5p01 000 330 onto the edge of the cylinder for clutch B. Put the measuring base on the highest point of the disc supporting surface on the piston and set the dial gauge to "0". Pull the measuring sensor upwards, guide it into the snap-ring groove and press it there against the groove's upper edge. Repeat measurement twice, turning by  $120^\circ$ .

Average measurement values  $B_1, B_2, B_3 \Rightarrow W_B$

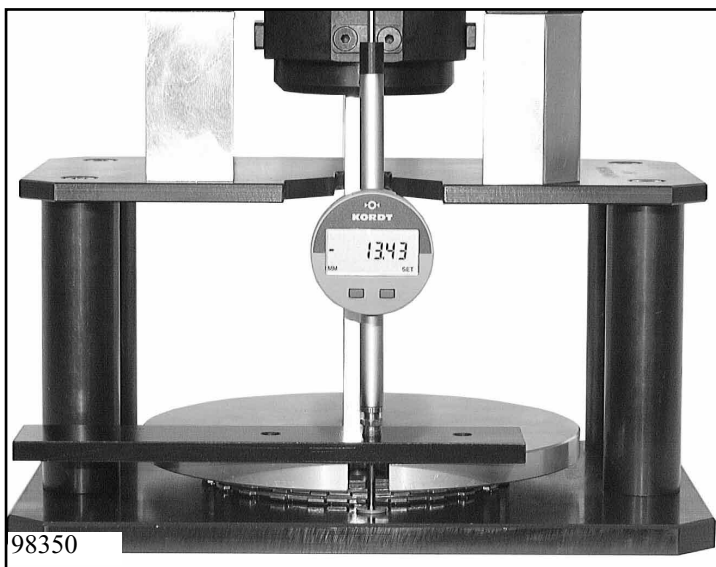

Determine thickness  $M_B$  of the clutch B disc pack according to Chapter 1.4.0: Measuring the disc pack.

$\Rightarrow M_B$

Installation space  $E_B$  is equal to  $W_B$  plus the thickness of the base  $F$ .  $\Rightarrow E_B$

The test value  $P_B$  is equal to installation space  $E_B$  minus  $M_B$ .

Value  $P_B$  should be between 2.02 - 3.14 mm  
**Test specification 1060 700 014**

Use test value  $P_B$  to select snap ring  $S_B$ .

**Calculation:**

$$E_B = W_B + F$$

$$P_B = E_B - M_B$$

Clutch clearance  $L_B$  should be 0.99 - 1.28 mm with 2 lined clutch discs.

**Example (for 1.4.6):**

$$F = 1.48 \text{ mm (base thickness)}$$

$$B_1 = 14.11 \text{ mm}$$

$$B_2 = 14.14 \text{ mm}$$

$$B_3 = 14.17 \text{ mm}$$

$$W_B = (14.11 + 14.14 + 14.17)/3 \\ = 14.14 \text{ mm}$$

$$M_B = 13.43 \text{ mm}$$

$$E_B = 14.14 + 1.48 \\ = 15.62 \text{ mm}$$

$$P_B = 15.62 - 13.43 \\ = 2.19 \text{ mm}$$

$$S_B = 1.2 \text{ mm}$$

$$L_B = 2.19 \text{ mm} - 1.2 \text{ mm}$$

$$\diamond L_B = 0.99 \text{ mm}$$

### 1.4.7 Adjusting clearance of brake C (snap ring)



Screw the cylinder to the oil supply using 2 M6 x 16 screws. (8 Nm)  
Determine installation space  $E_C$  for brake C with measuring bar 5p01 000 330. To do this, put measuring bar 5p01 000 330 onto the edge of the cylinder for brake C. Put the measuring base on the highest point of the disc supporting surface on the piston and set the dial gauge to "0". Pull the measuring sensor upwards, guide it into the snap-ring groove and press it there against the groove's upper edge. Repeat measurement twice, turning by  $120^\circ$ . Average measurement values  $C_1, C_2, C_3 \Rightarrow W_C$

#### Note:

Remove the screws afterwards.

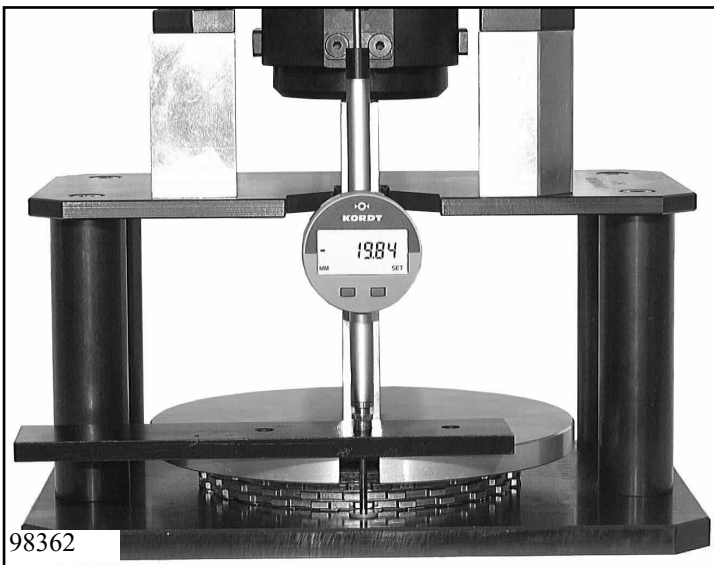

Determine thickness  $M_C$  of the brake C disc pack according to **Chapter 1.4.0: Measuring the disc pack.**

$\Rightarrow M_C$

Installation space  $E_C$  is equal to  $W_C$  plus the thickness of the base  $F$ .  $\Rightarrow E_C$

Test value  $P_C$  is equal to installation space  $E_C$  minus  $M_C$ .

The  $P_C$  value should be between 2.51 - 3.70 mm

**Test specification 1060 700 013**

Version A

Use test value  $P_C$  to select snap ring  $S_C$ .

#### Calculation:

$$E_C = W_C + F$$

$$P_C = E_C - M_C$$

Clutch clearance  $L_C$  should be 1.30 - 1.60 mm with 3 lined clutch discs.

**Example (for 1.4.7):**

$$F = 1.48 \text{ mm (base thickness)}$$

$$C_1 = 21.35 \text{ mm}$$

$$C_2 = 21.37 \text{ mm}$$

$$C_3 = 21.39 \text{ mm}$$

$$W_C = (21.35 + 21.37 + 21.39)/3 \\ = 21.37 \text{ mm}$$

$$M_C = 19.84 \text{ mm}$$

$$E_C = 21.37 + 1.48 \\ = 22.85 \text{ mm}$$

$$P_C = 22.85 - 19.84 \\ = 3.01 \text{ mm}$$

$$S_C = 1.6 \text{ mm}$$

$$L_C = 3.01 \text{ mm} - 1.6 \text{ mm}$$

$$\Rightarrow L_C = 1.41 \text{ mm}$$



### 1.4.8 Output play (shim)

With the measuring bar at a distance of about 140 mm, insert an approximately 20-mm thick gauge block underneath. On the gauge plate, set the dial gauge to "0".

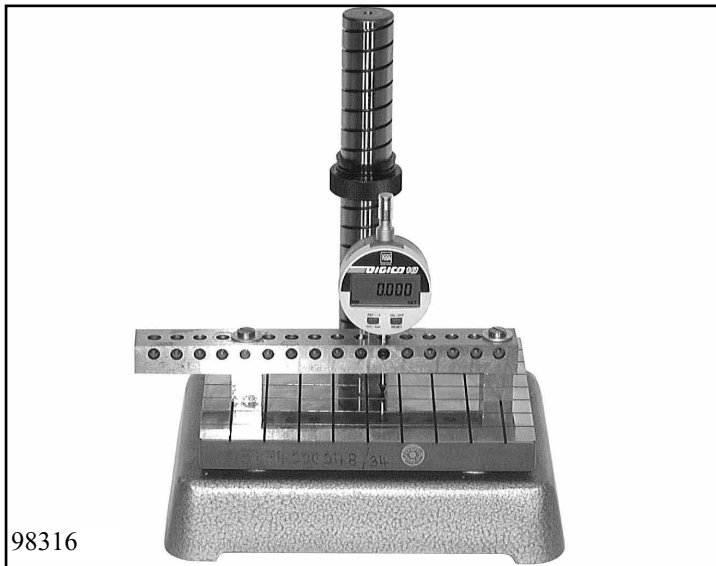

98316

Place output assembly on device 5x46 002 089.

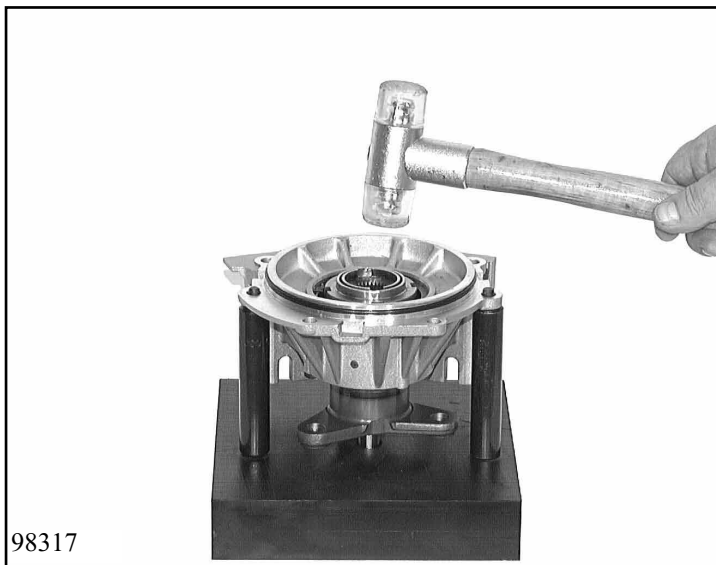

98317

#### **Important !**

To prevent distortion of measured values, do not place on output flange. Move the output flange in the output direction to a position where it is free from play.

Determine dimension A between the machined surface of the extension and the hub of the output flange.

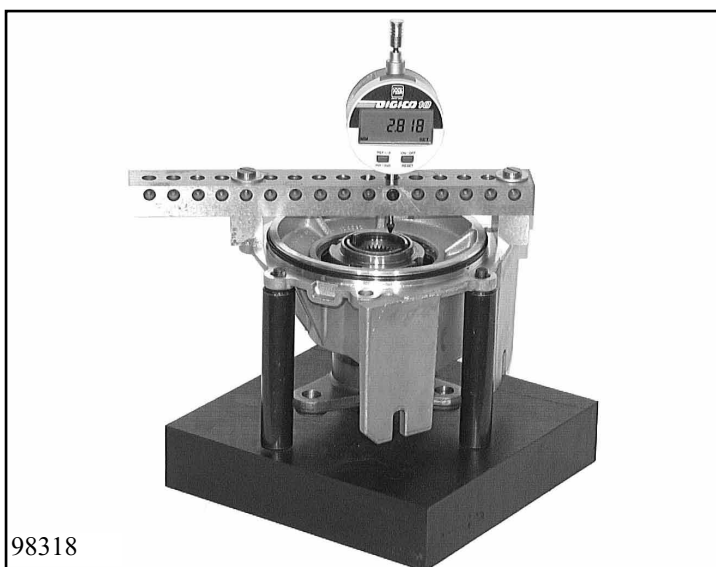

98318

Using a depth gauge, determine dimension B between the machined surface of the transmission housing and the machined surface of the parking lock wheel. According to the parts list, play C should be 0.15 to 0.35 mm.

The test dimension is 0.1 to 0.4 mm.

**Test specification 1060 700 204.**

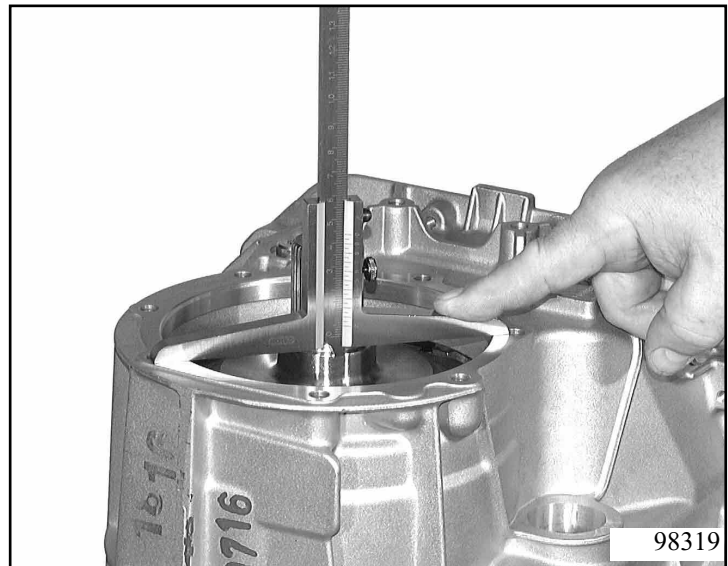

Thickness of washer **S** is now equal to **B** minus **A** minus **C**.

**Calculation:**

$$S = B - A - C$$

**Example: (for 1.4.8)**

$$A = 2.818 \text{ mm}$$

$$B = 4.8 \text{ mm}$$

$$C = 0.15 \text{ to } 0.35 \text{ mm}$$

$$S = 4.8 - 2.818 - (0.15 \text{ to } 0.35)$$

$$= 1.982 - (0.15 \text{ to } 0.35)$$

$$= 1.632 \text{ to } 1.832 \text{ mm}$$

**Chosen:**

$$\Rightarrow S = 1.7 \text{ mm}$$

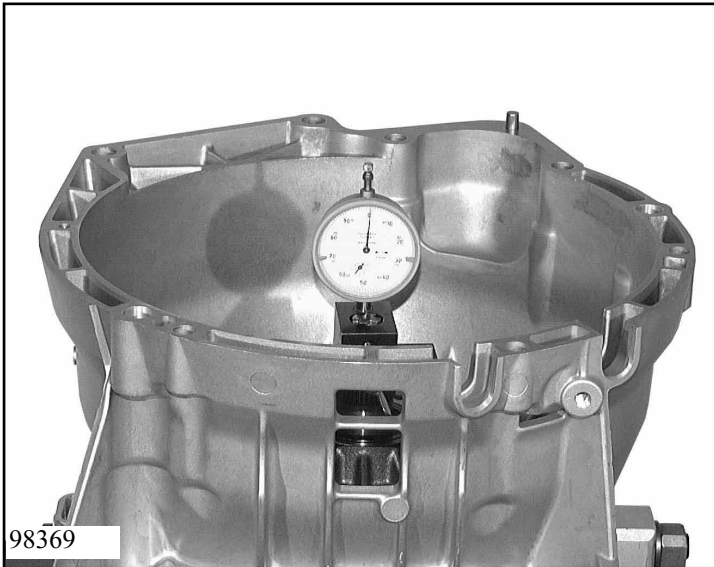

### 1.4.9 Input play (shim)

Fasten the oil supply using at least 2 opposite machine screws.

(For tightening torque, see Chapter 1.5)

Clamp measuring device 5p01 002 379 to input shaft with a fixing screw at about 2 mm above the stator shaft so that there is no play. Set gauge to 0.

#### Requirement:

Axial needle roller bearing 10.390 and thinnest shim 10.400 ( $S_D = 1$  mm) must be in place.

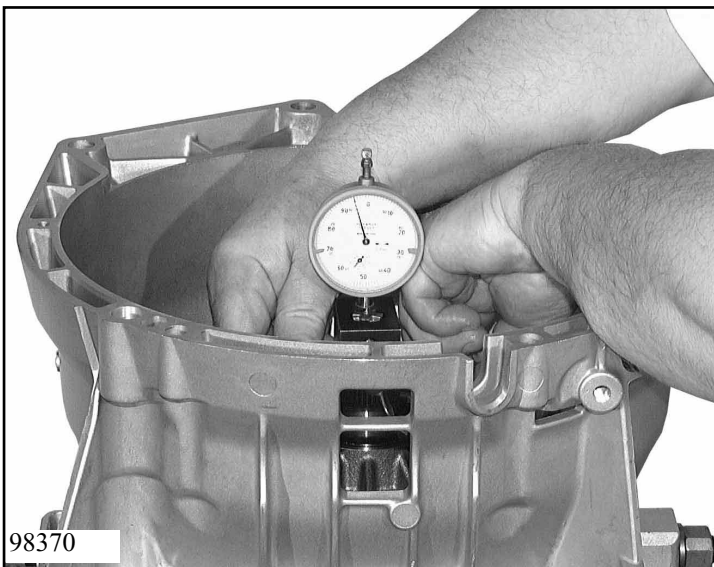

Determine axial play by pressing and pulling on the handle (repeat measurement).

Nominal axial play  $D = 0.05 - 0.35$  mm in accordance with **Test specification 1056 700 203**.

Take average of measured values  $M_1, M_2$   
 $\Leftrightarrow M$

#### Formula:

$$M = (M_1 + M_2) / 2$$

$$S = M + S_D - D$$

If there is a deviation, insert a thicker shim 10.400.

To do this, *remove oil supply and input assembly* and insert the new shim instead of the one used in the first measurement.

Then re-insert in accordance with *3.Fitting the input assembly with oil supply*.

Re-check axial play.

**Example: (for 1.4.8)**

$$M_1 = 0.88 \text{ mm}$$

$$M_2 = 0.86 \text{ mm}$$

$$S_D = 1.00 \text{ mm}$$

$$D = 0.05 \text{ to } 0.35 \text{ mm}$$

$$M = (0.88 + 0.86) / 2 = 0.87 \text{ mm}$$

$$S = 0.87 + 1.00 - (0.05 \text{ to } 0.35)$$

$$= 1.87 - (0.05 \text{ to } 0.35)$$

$$= 1.52 \text{ to } 1.82 \text{ mm}$$

**Chosen:**

$$\square S = 1.7 \text{ mm}$$

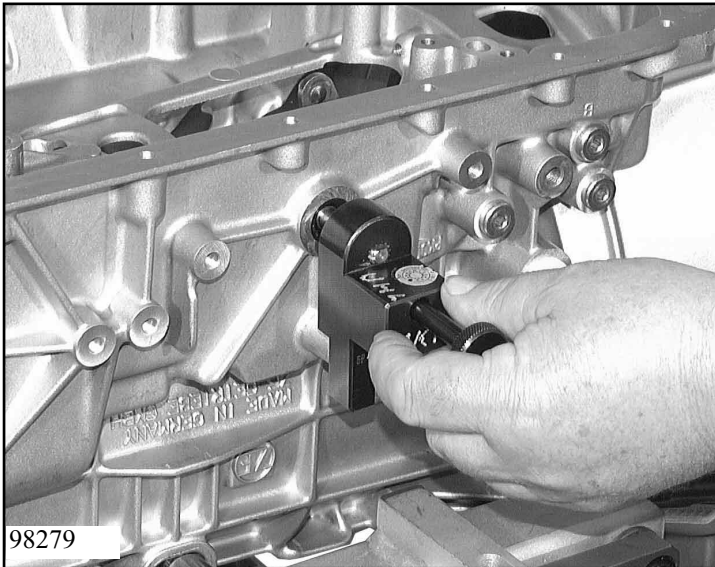

#### 1.4.10 Adjusting the switch (detent spring)

Move the detent disc to the N (neutral) position with a suitable tool or by hand.

Place position gauge 5p01 002 321 on the selector shaft, turn the position gauge so that the locating pin in the transmission housing enters the cutout in the position gauge and eliminate any play by turning the knurled screw.

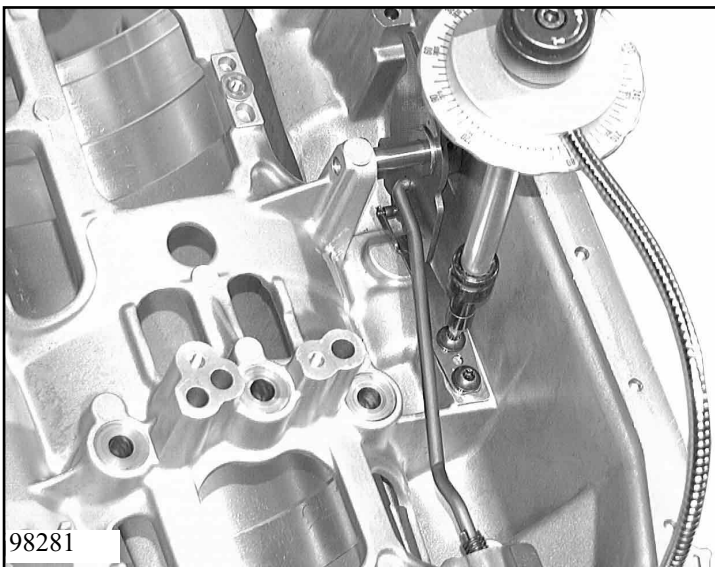

Align the roller of the detent spring at right angles to the detent disc and screw the spring tight in this position using auxiliary tool 5w04 000 583.

(See Chapter 1.5 for tightening torque)

Release the position gauge and move the selector shaft through all the positions, then back to N.

If installation has been performed correctly, the position gauge can easily be placed on the selector shaft until it comes into contact with the transmission housing.



## 1.5 Tightening torques

No.	Designation	Part List- Item-No.	Wrench size No.	Page	Tightening torque [Nm]
1	Screw plug M10x1 (transmission housing)	01.650	Hexagonal socket SAF = 5 mm	3.1/1	12 Nm (±1.2 Nm)
2	Screw plug M18x1.5 (transmission housing)	01.010/340	Hexagonal socket SAF = 8 mm	3.1/1	35 Nm (±3.5 Nm)
3	Machine screw (detent spring)	01.010/150	TORX - TX 27 H	1.4/21 3.1/1	10 Nm + 30° (±0.3 Nm ±10°)
4	Screw plug (torsion spring)	01.090	Hexagonal socket SAF = 6 mm	3.1/2	20 Nm (±2.0 Nm)
5	Machine screw (guide plate)	01.080	TORX - TX 27	3.1/3	10 Nm (±1.0 Nm)
6	Machine screw (tower)	73.200	TORX - TX 50	1.3/1 3.2/7	63 Nm (±1.5 Nm)
7	Slotted nut (output)	14.040	Socket wrench 5X46 000 541	3.3/2	120 Nm (±12.0 Nm)
8	Hexagon screw (output)	14.110	SAF = 13 mm	3.3/3	23 Nm (±2.3 Nm)
9	Countersunk screw (stator shaft/centering plate)	10.060/130	TORX - TX 27	1.3/1 3.6/2	10 Nm (±1.0 Nm)
10	Countersunk screw (intermediate plate/pump)	10.100	TORX - TX 27	1.3/1 3.6/2	10 Nm (±1.0 Nm)
11	Countersunk screw (intermediate plate/pump)	10.120	TORX - TX 27	1.3/1 3.6/2	10 Nm (±1.0 Nm)
12	Countersunk screw (intermediate plate/pump)	10.160	TORX - TX 27	1.3/1 3.6/2	6 Nm (±0.6 Nm)
13	Machine screw (oil supply)	10.040	TORX - TX 27	1.4/19 3.7/3	10 Nm (±1.0 Nm)
14	Machine screw (Hall-effect sensor)	28.030	TORX - TX 27	3.8/1	9 Nm (±0.9 Nm)
15	Machine screw (inductive transmitter)	28.060	TORX - TX 27	3.8/2	6 Nm (±0.6 Nm)

No.	Designation	Part List- Item-No.	Wrench size No.	Page	Tightening torque [Nm]
16	Machine screw (control unit)	28.410	TORX - TX 27	3.8/4	8 Nm (±0.8 Nm)
17	Machine screw (filter)	28.440	TORX - TX 27	3.8/4	6 Nm (±0.6 Nm)
18	Machine screw (oil pan)	03.040	TORX - TX 27	3.8/4	10 Nm (±1.0 Nm)
19	Screw plug M16x1.5 (oil pan)	03.010/130	Hexagonal socket SAF = 8 mm	3.8/5	30 Nm (±3.0 Nm)
20	Hexagon screw (cable clip)	01.560	SAF = 10mm	3.9/1	10 Nm (±1.0 Nm)
21	Hexagon screw (switch)	01.570	SAF = 10 mm	3.9/2	10 Nm (±1.0 Nm)
22	Hexagon screw M10x55 (converter retaining bracket)		SAF = 17 mm	3.9/3	20 Nm (±2.0 Nm)
23	Hexagon screw M10x16 (converter retaining bracket)		SAF = 17 mm	3.9/3	20 Nm (±2.0 Nm)



## **1.6 Transmission test (test bench)**

The following points must be checked:

### **Correct oil level**

Proper oil level; observe the vehicle manufacturer's specifications and ELCAT.

### **Oil level too low**

This can result in:

- Engine over-revving or no power flow in curves or when starting from a stop
- Valve chatter due to air pockets in the oil
- General malfunctions

Among other things, burned clutches can be the result.

### **Oil level too high**

Danger of loss due to splashing, formation of foam, strong temperature increases at high road speeds. Loss of oil via breather; among other things, burned clutches and shifting problems can be the result.

### **Proper engine settings**

Correct idle speed; follow specifications from vehicle manufacturer.

### **Power flow, forward and reverse**

Correct adjustment of selector linkage or cable control; observe the vehicle manufacturer's specifications.



### **Cooler bypass respectively cooler connection on test bench**



Do not overheat transmission, maximum +120° C

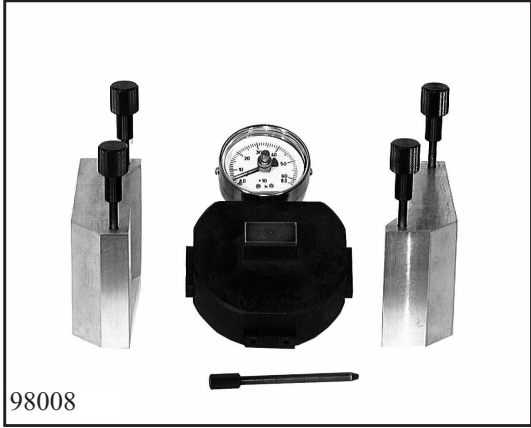
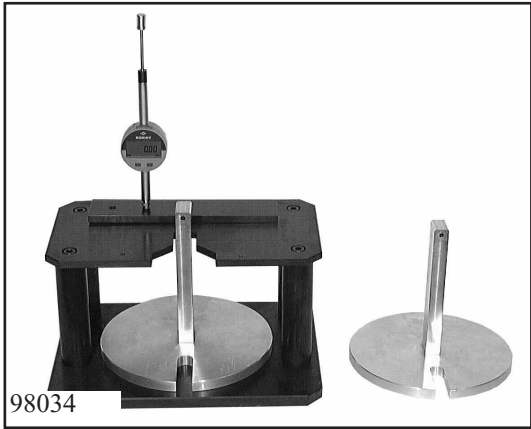
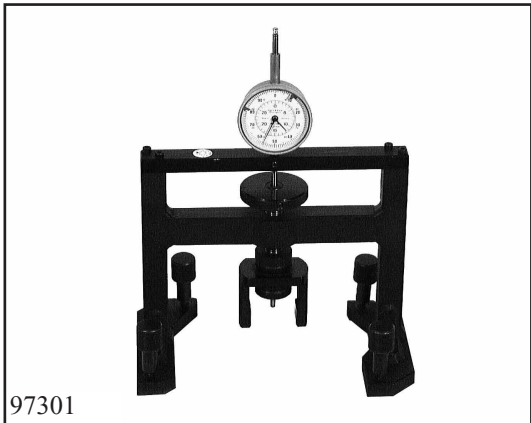

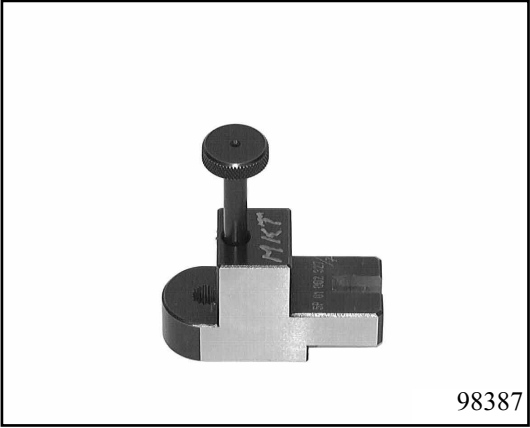

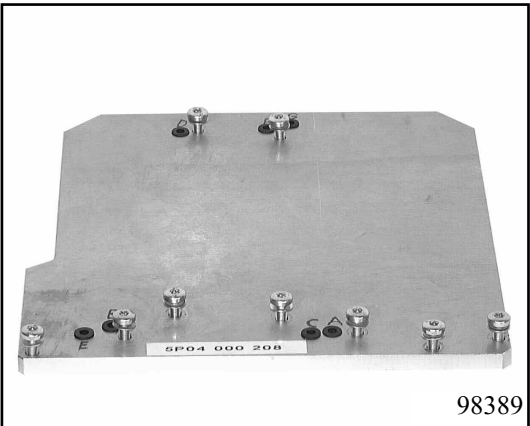

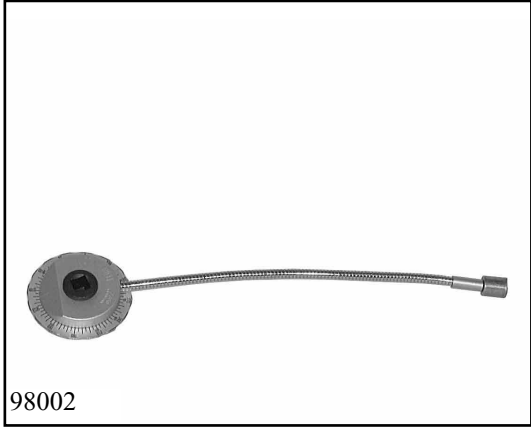
## 1.7 Special tools



OBJECT	Order-No. / Application	Remarks
<p style="text-align: center;">1</p>  <p>98008</p>	<p>5p01 000 329 - Force measuring unit</p>	<p>Identical</p> <p>4 HP 20 5 HP 24</p>
<p style="text-align: center;">2</p>  <p>98034</p>	<p>5p01 000 330 - Measurement device for clutch pack play</p> <p>(measuring plate: - short neck &gt;20 mm - long neck &lt;20 mm disc pack thickness)</p>	<p>Identical</p> <p>4 HP 20 5 HP 24</p>
<p style="text-align: center;">3</p>  <p>97301</p>	<p>5p01 001 458 - Measurement device, bearing play</p> <p>- Measurement device, clearance (top piece)</p>	<p>Identical</p> <p>4 HP 18 Q 4 HP 20 5 HP 24</p>

Remarks	Order-No. / Application	OBJECT
	<p>5p01 002 327 - Adjustment tool, detent spring</p> <p>5p01 002 379 - Measurement device for axial play</p> <p>5p04 000 208 - - Test plate for clutches A-G</p>	<p style="text-align: center;"><b>4</b></p> <div style="text-align: center;">  <p>98387</p> </div> <p style="text-align: center;"><b>5</b></p> <div style="text-align: center;">  <p>98388</p> </div> <p style="text-align: center;"><b>6</b></p> <div style="text-align: center;">  <p>98389</p> </div>

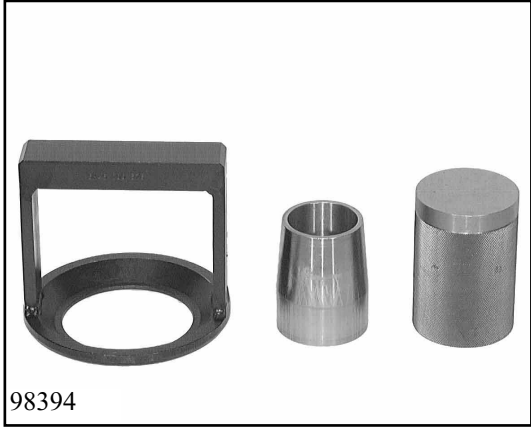

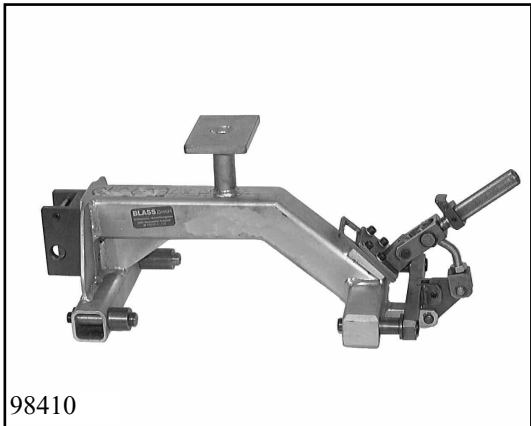
OBJECT	Order-No. / Application	Remarks
<p style="text-align: center;">7</p> <div style="border: 1px solid black; padding: 10px;">  <p>98002</p> </div>	<p>5w04 000 583 - Torque measuring unit (Stahlwille 7380)</p>	<p>Identical  5 HP 24</p>
<p style="text-align: center;">8</p> <div style="border: 1px solid black; padding: 10px;">  <p>97305</p> </div>	<p>5x46 030 167 - Assembly bracket for pressing down cup spring E  (equivalent to part 3 of device 5x46 000 167)</p>	<p>Identical  4 HP 14 Q 4 HP 18 Q 4 HP 20 4 HP 22 5 HP 18 5 HP 24</p>
<p style="text-align: center;">9</p> <div style="border: 1px solid black; padding: 10px;">  <p>98135</p> </div>	<p>5x46 000 306 - Sleeve for pump test</p>	<p>Identical  4 HP 18 Q</p>

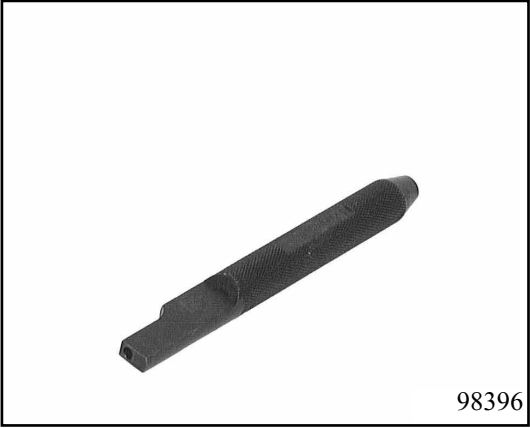

Remarks	Order-No. / Application	OBJECT
	5x46 000 422 - Drift for removing output flange	<p style="text-align: center;"><b>10</b></p> <div style="border: 1px solid black; padding: 10px; text-align: center;">  <p style="text-align: right;">98391</p> </div>
Identical  5 HP 18	5x46 000 541 - Slotted-nut wrench	<p style="text-align: center;"><b>11</b></p> <div style="border: 1px solid black; padding: 10px; text-align: center;">  <p style="text-align: right;">98392</p> </div>
Identical  5 HP 18	5x46 000 545 - Lifting device for tower	<p style="text-align: center;"><b>12</b></p> <div style="border: 1px solid black; padding: 10px; text-align: center;">  <p style="text-align: right;">98393</p> </div>

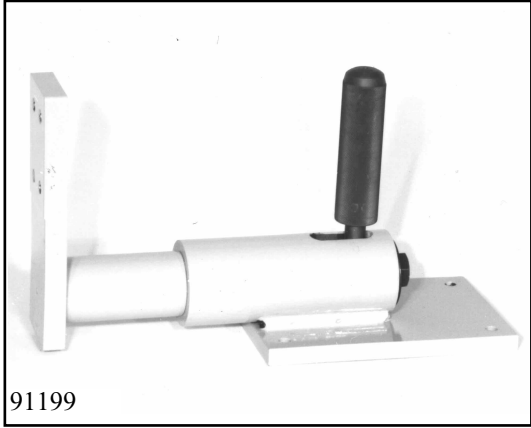

OBJECT	Order-No. / Application	Remarks
<p style="text-align: center;"><b>13</b></p>  <p>98394</p>	<p>5x46 000 576 - Assembly bracket, taper, thrust piece, brake C and G</p>	<p>identical 5 HP 18</p>
<p style="text-align: center;"><b>14</b></p>  <p>98395</p>	<p>5x46 000 577 - Counter support</p>	<p>identical 5 HP 18</p>
<p style="text-align: center;"><b>15</b></p>  <p>98410</p>	<p>5x46 000 620 - Assembly bracket, transmission, complete</p>	<p>identical 5 HP 18</p>

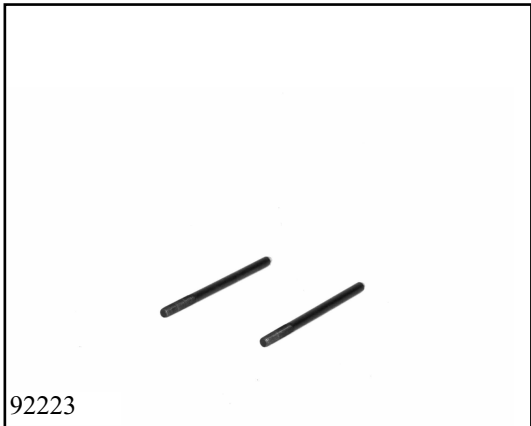

Remarks	Order-No. / Application	OBJECT
<p>identical</p> <p>5 HP 18</p>	<p>5x46 000 685</p> <p>- Drift for dowel pin in the selector shaft</p>	<p style="text-align: center;"><b>16</b></p>  <p style="text-align: right;">98396</p>
<p>identical</p> <p>5 HP 18</p>	<p>5x46 000 760</p> <p>- Press-in fixture for angular ball bearing, transmission extension</p>	<p style="text-align: center;"><b>17</b></p>  <p style="text-align: right;">98397</p>
<p>identical</p> <p>5 HP 18</p>	<p>5x46 000 761</p> <p>- Drift, shaft seal for transmission extension</p>	<p style="text-align: center;"><b>18</b></p>  <p style="text-align: right;">98398</p>





OBJECT	Order-No. / Application	Remarks
<p style="text-align: center;"><b>19</b></p>  <p>91199</p>	<p>5x46 000 763 - Work bench holder for assembly bracket</p>	<p>identical  5 HP 18 5 HP 24 5 HP 30</p>
<p style="text-align: center;"><b>20</b></p>  <p>91188</p>	<p>5x46 000 946 - Counter support for output flange</p>	<p>identical  5 HP 24 5 HP 30</p>
<p style="text-align: center;"><b>21</b></p>  <p>92223</p>	<p>5x46 001 007 - Locating pin for oil supply (2 items)</p>	<p>identical  5 HP 24 5 HP 30</p>

Remarks	Order-No. / Application	OBJECT
	<p>5x46 002 004 - Assembly bracket for pressing down cup spring A</p> <p>5x46 002 005 - Assembly bracket for pressing down cup spring B + F</p> <p>5x46 002 006 - Supporting fixture for tower</p>	<p style="text-align: center;"><b>22</b></p> <div style="text-align: center;">  <p style="text-align: right;">98399</p> </div> <p style="text-align: center;"><b>23</b></p> <div style="text-align: center;">  <p style="text-align: right;">98400</p> </div> <p style="text-align: center;"><b>24</b></p> <div style="text-align: center;">  <p style="text-align: right;">98401</p> </div>

OBJECT	Order-No. / Application	Remarks
<p style="text-align: center;"><b>25</b></p>  <p>98402</p>	<p>5x46 002 007 - Centering device, brake C (with centering pin and wedge)</p>	
<p style="text-align: center;"><b>26</b></p>  <p>98403</p>	<p>5x46 002 008 - Assembly drift for shaft seal, pump</p>	
<p style="text-align: center;"><b>27</b></p>  <p>98404</p>	<p>5x46 002 009 - Removal device, oil supply</p>	

Remarks	Order-No. / Application	OBJECT
	<p>5x46 002 010 - Assembly device, oil supply with input assembly</p> <p>5x46 002 088 - Removal device, piston F</p> <p>5x46 002 089 - Assembly device, extension</p>	<p style="text-align: center;"><b>28</b></p> <div style="text-align: right; margin-right: 20px;">98405</div>  <p style="text-align: center;"><b>29</b></p> <div style="text-align: right; margin-right: 20px;">98406</div>  <p style="text-align: center;"><b>30</b></p> <div style="text-align: right; margin-right: 20px;">98407</div> 

OBJECT	Order-No. / Application	Remarks
<p style="text-align: center;"><b>31</b></p> <div data-bbox="178 472 711 898" style="border: 1px solid black; padding: 5px;">  <p data-bbox="185 860 256 887">76046</p> </div>	<p data-bbox="767 427 951 461">5x56 000 090</p> <p data-bbox="767 465 1078 539">- Extracting handles for converter (2 items)</p>	<p data-bbox="1262 427 1382 461">Identical</p> <p data-bbox="1262 506 1374 539">3 HP 22</p> <p data-bbox="1262 544 1374 577">4 HP 22</p> <p data-bbox="1262 582 1374 616">5 HP 18</p> <p data-bbox="1262 620 1374 654">5 HP 24</p> <p data-bbox="1262 658 1374 692">5 HP 30</p>
<p style="text-align: center;"><b>32</b></p> <div data-bbox="178 1032 711 1458" style="border: 1px solid black; padding: 5px;">  <p data-bbox="185 1420 256 1447">98408</p> </div>	<p data-bbox="767 987 951 1021">5x95 000 038</p> <p data-bbox="767 1025 1182 1059">- Drift, shaft seal, selector shaft</p>	



## 2. Removing assemblies

### 2.1 Removing the converter, oil pan and automatic control unit

Place complete transmission in assembly bracket 5x46 000 620 with the oil pan at the bottom and mount on assembly trolley or work bench holder 5X46 000 763.

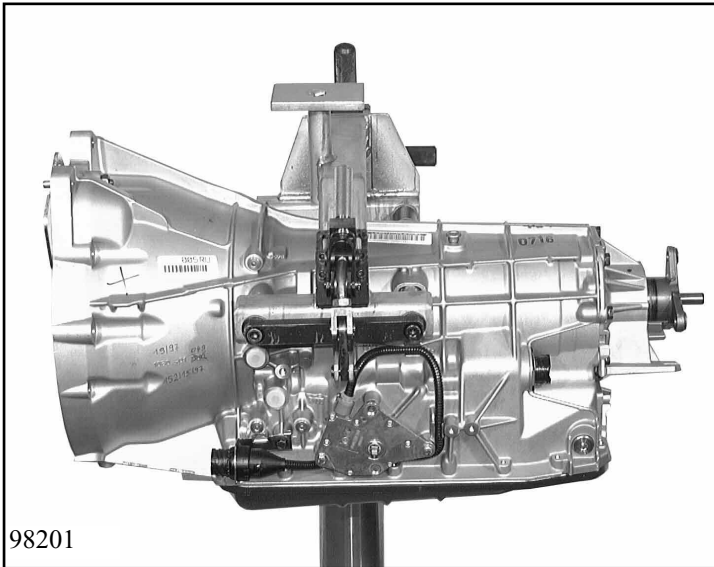

Unscrew the oil inlet/drain plug and drain off the oil.

(SAF hexagonal socket = 8 mm)

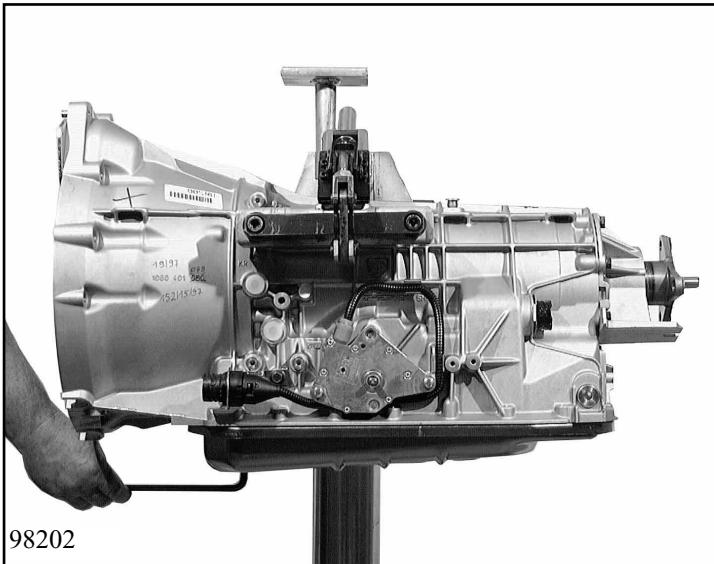

Remove the converter retaining bracket and remove the converter using two extractor handles 5x56 000 090.

(SAF = 17 mm)

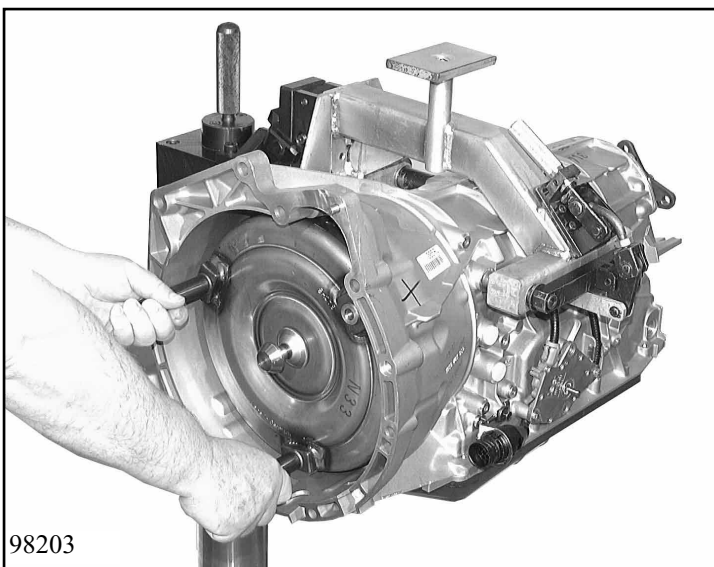

Turn the transmission by 180°.  
Unscrew the 22 screws used to fasten the oil pan and remove it.  
Remove the gasket from the transmission housing.  
Remove the magnets from the oil pan.

(Wrench size = Torx TX 27)

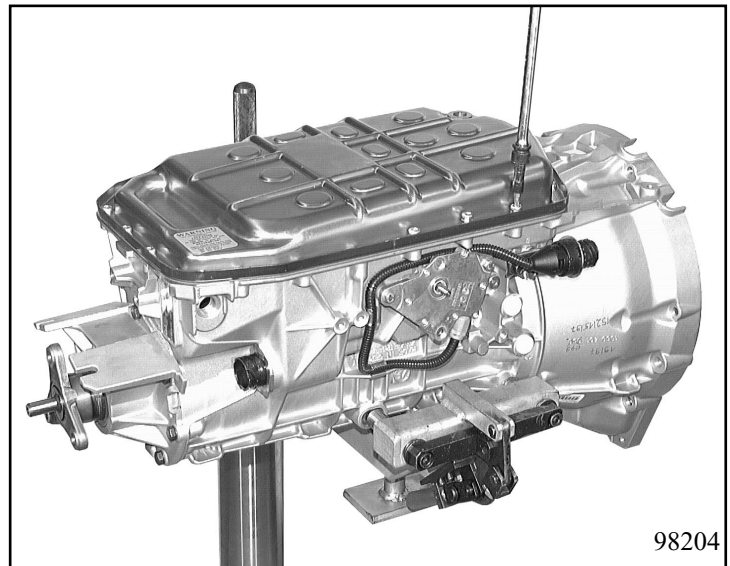

Unscrew the 2 screws used to fasten the oil filter and remove it.

(Wrench size = Torx TX 27)

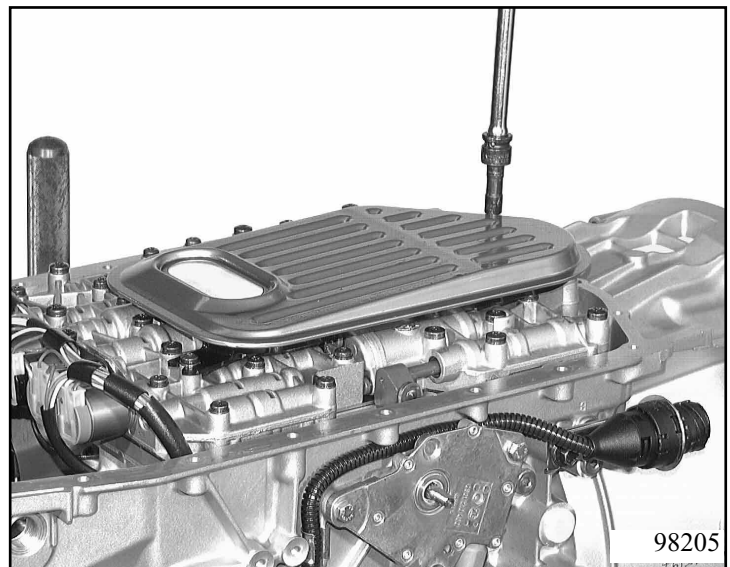

Remove retaining plate from the wiring harness plug and insert the plug into the transmission.

Unscrew the 2 screws of the inductive transmitter (output speed) and remove the transmitter.

(Wrench size = Torx TX 27)

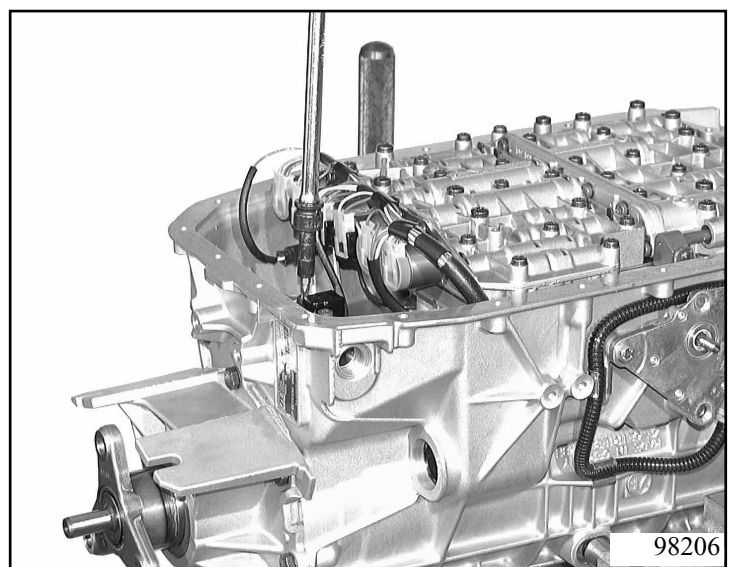



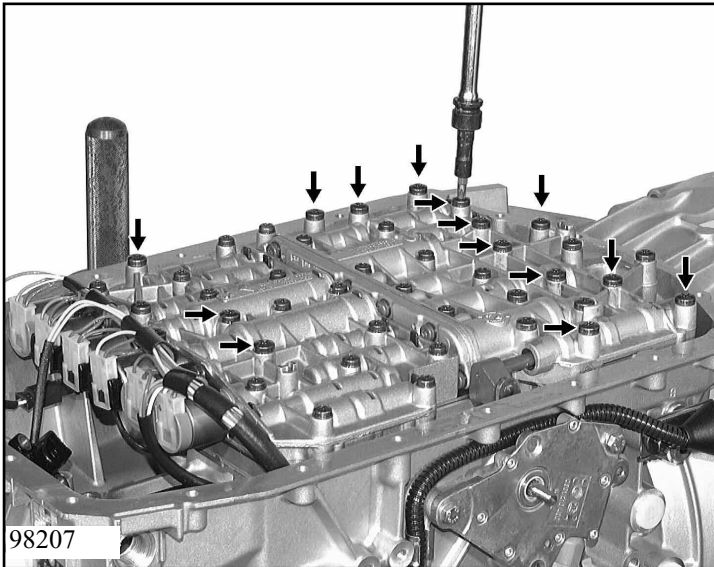

Unscrew the 14 screws with large heads as shown on the left and place the automatic control unit at an angle on the transmission housing.

(Wrench size = Torx - TX 27)

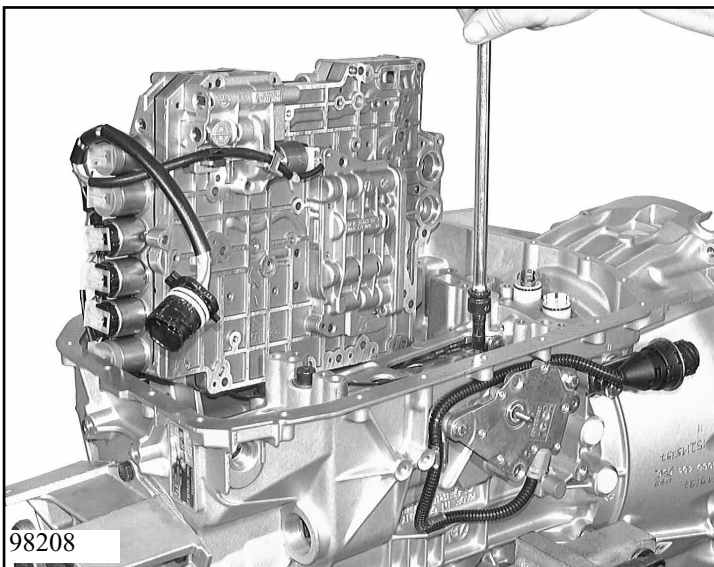

Unscrew the screw of the Hall-effect sensor and pull the wiring harness leading to the sensor out of the retaining groove. Lift out the control unit.

(Wrench size = Torx - TX 27)

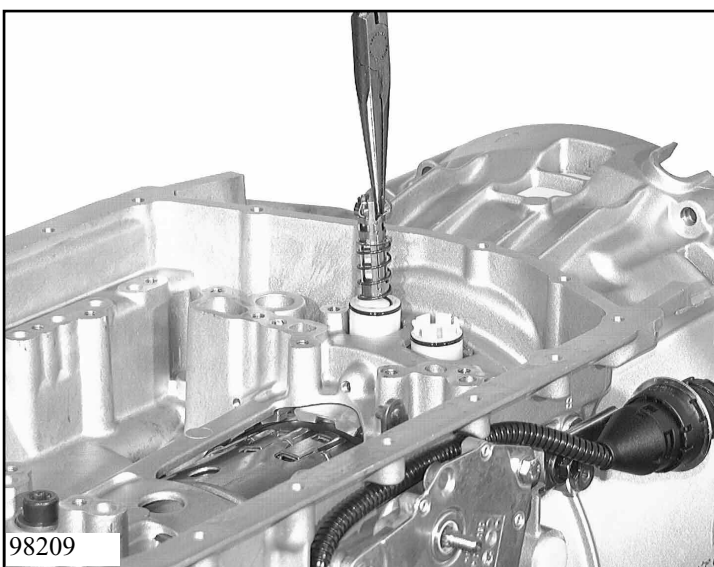

To release the sleeve of the flow control valve, press down and twist. Remove the sleeve and spring.

Remove the 2 plastic tubes from the transmission housing with a suitable tool.

Remove the piston of the flow control valve with long-nosed pliers.

Release position switch cable plug with pliers and push out of retaining bracket. Pull cable out of retaining clips. Move selector shaft to N. Remove position switch screws and remove position switch

(SAF = 10 mm)

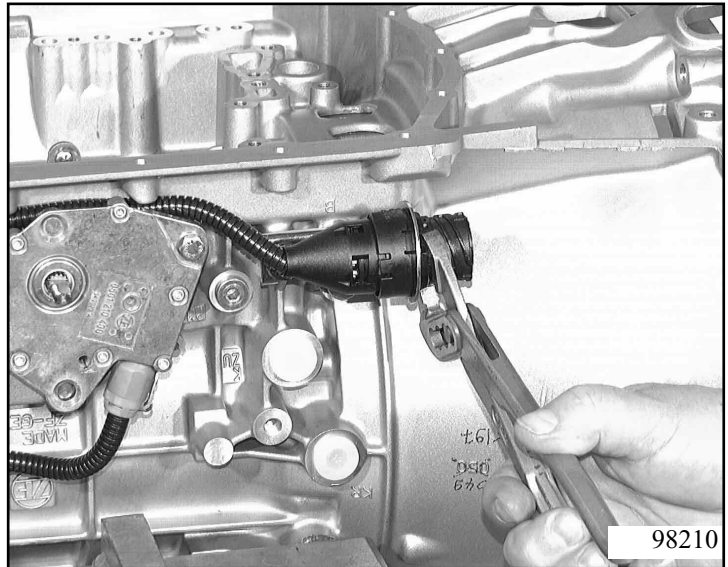

Unscrew and remove the wiring harness retaining bracket. Remove 2 retaining clips.

(SAF = 10 mm)

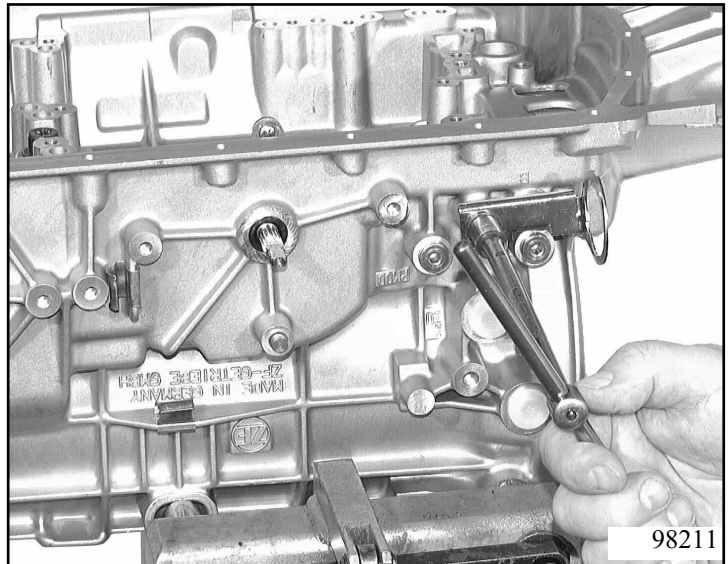

Drive the clamping sleeve out of the selector shaft and remove the selector shaft. Remove the detent disc and connector rod and release the rod from the disc. Remove the shaft seal with a suitable tool.

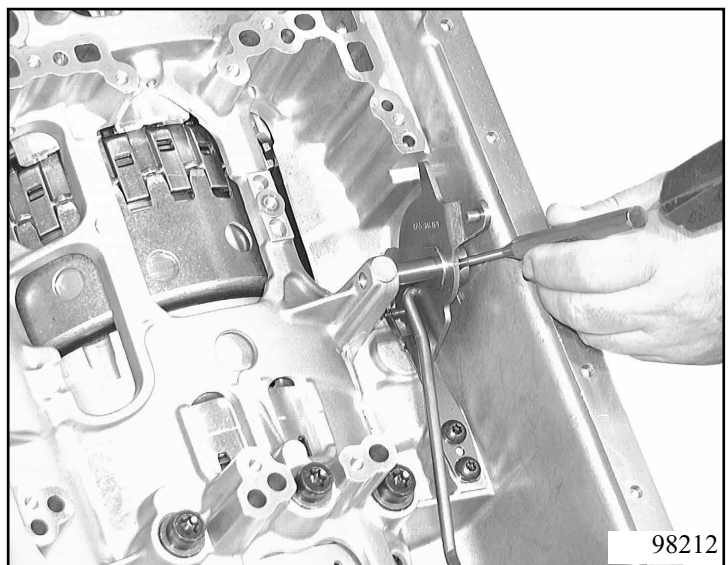

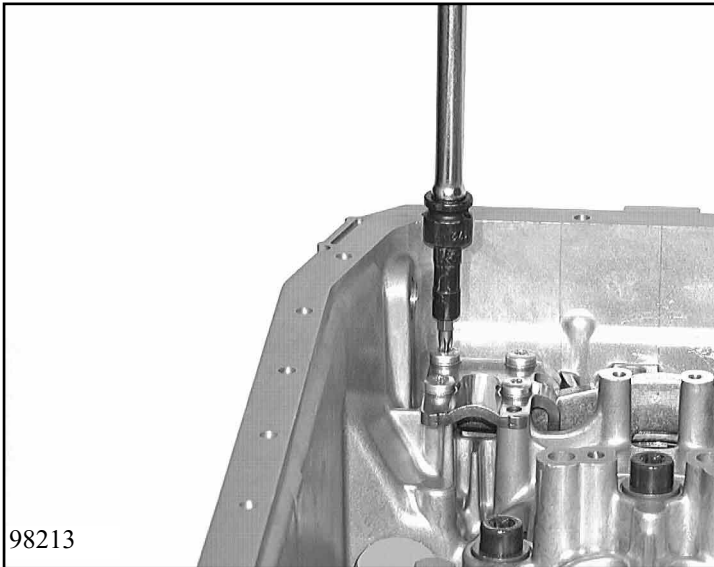

Unscrew the 4 screws of the guide plate and remove the guide plate.

(Wrench size = Torx TX 27)

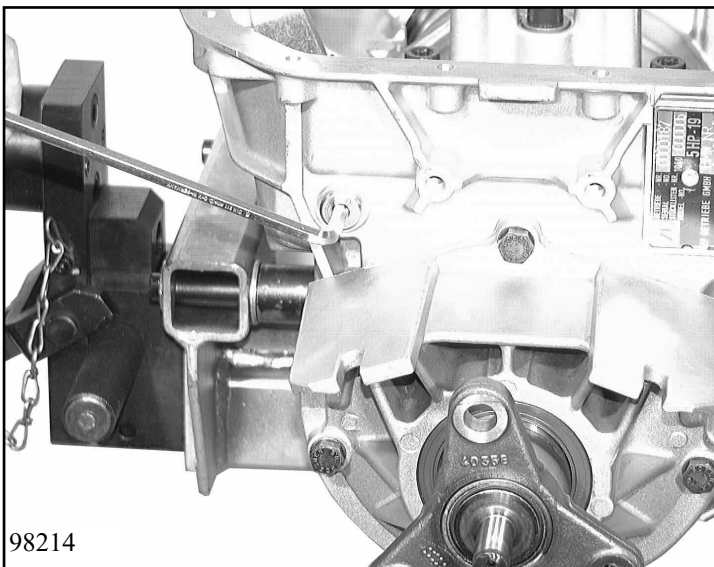

Unscrew the guide pin screw plug. Remove the guide pin and take out the pawl together with the torsion spring.

(SAF hexagonal socket = 6 mm)

**Please note:**

The detent spring should normally be left in place.





## 2.2 Removing the oil supply

Turn the transmission by 90°.  
Remove the 9 screws holding the oil supply.

Clamp device 5x46 002 009 to stator shaft.

Turn the spindle of the device so that it points downwards and lift out the complete oil supply unit.

Remove the axial adjustment washer and needle cage.

(Wrench size = Torx TX 27)



### 2.3 Removing the input assembly

Lift out the input shaft together with clutches A, B and E, either by hand or using device 5x46 002 010.



Remove the 2 thrust washers and the needle cage.  
Lift out the intermediate shaft.



Remove the angle washer, needle cage and thrust washer.  
Remove the sun shaft and the axial needle cage.

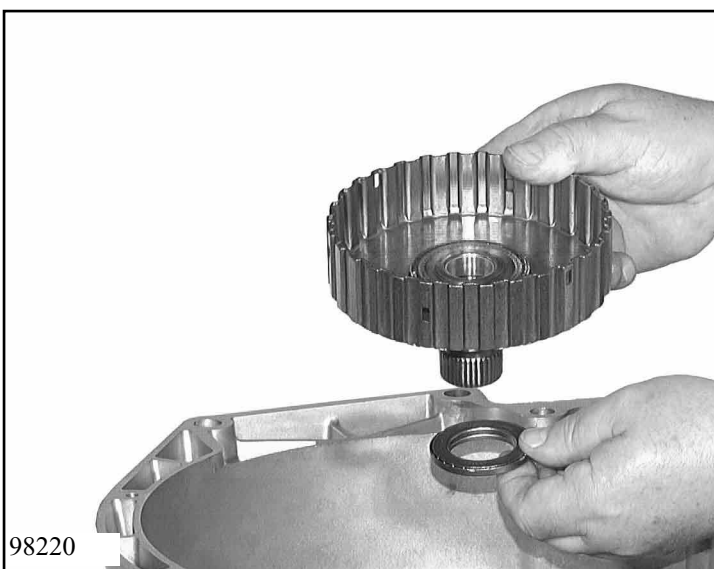

Remove the sun wheel, planetary gear set, angle washer, needle cage and thrust washer.

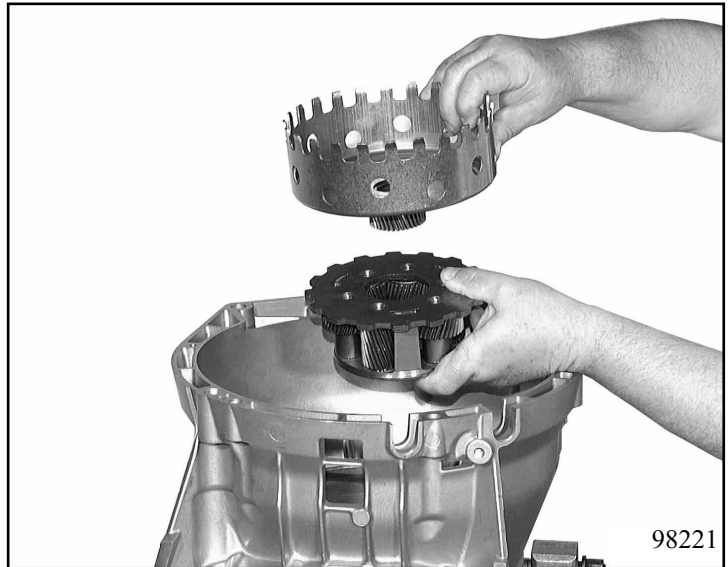

Remove the shaft with the ring gear, thrust washer, needle cage, angle washer and cup.





## 2.4 Removing the tower

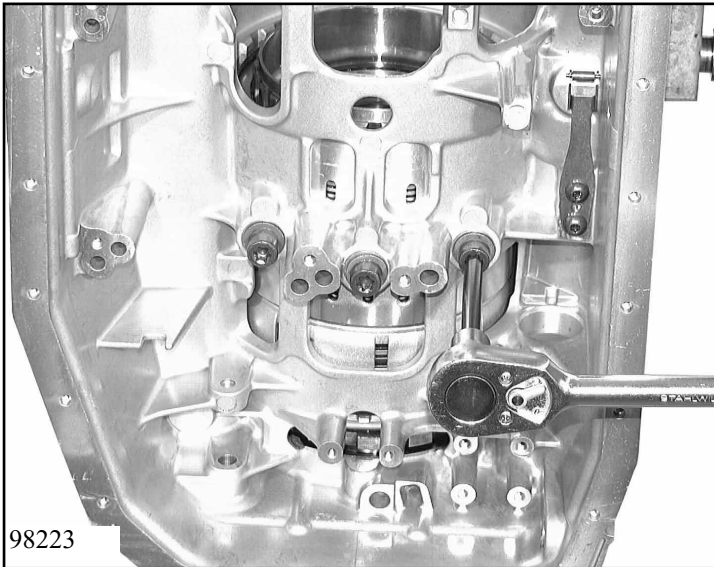

Remove the 3 machine screws and lift out the tower.  
Insert lifting device 5x46 000 545 into the tower's planet carrier and lock in the centre by pressing down the clamping device.

(Wrench size = Torx TX 50)

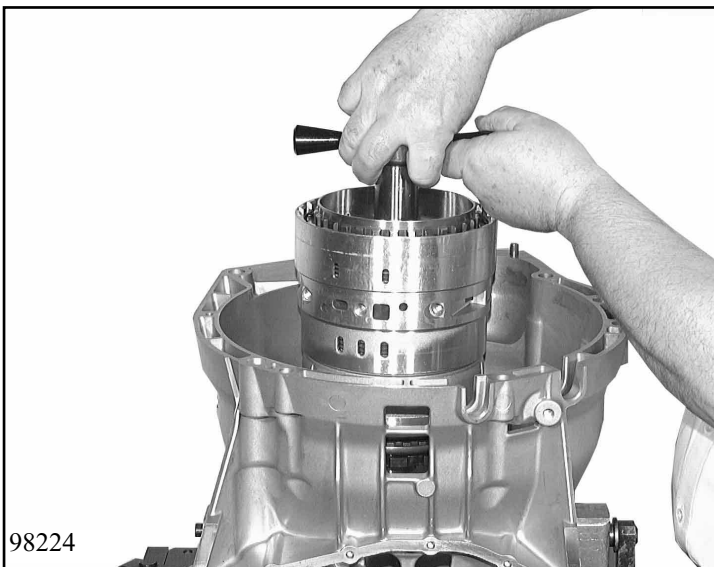

Lift out the tower and insert into holding device 5x46 002 006.  
Remove the shim.

**Please note:**  
Shim may stick in the tower.





## 2.5 Removing the output assembly.

Turn the transmission by 180° and undo the 7 screws holding the transmission extension.

(SAF = 13 mm)



Remove the transmission extension.

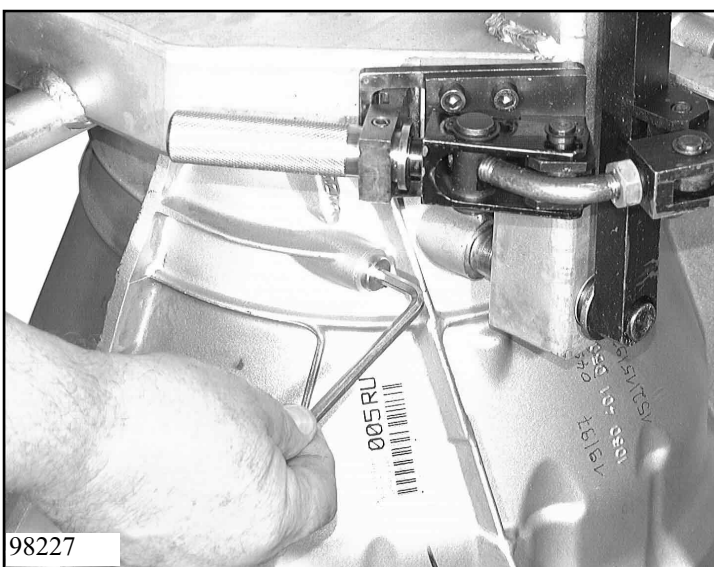

Remove all (screw) plugs from the transmission housing.  
Remove breather cover.

(SAF hexagonal socket = 5 mm)



## Disassembly

### 2.6 Output assembly

#### Using a vice:

Insert output assembly into device 5X46 000 946. Remove O-ring from output. Release slotted nut with a drift.



Apply slotted-nut wrench 5x46 000 541 to slotted nut, unscrew and remove.



Place output assembly on device 5x46 002 089. Drive out output flange with drift 5x46 000 422 and plastic-faced hammer.



Remove retaining ring with suitable pliers.  
Remove bearing inner race and lever out the shaft seal.



Push out the remaining components of the double bearing with a suitable mandrel in a press.

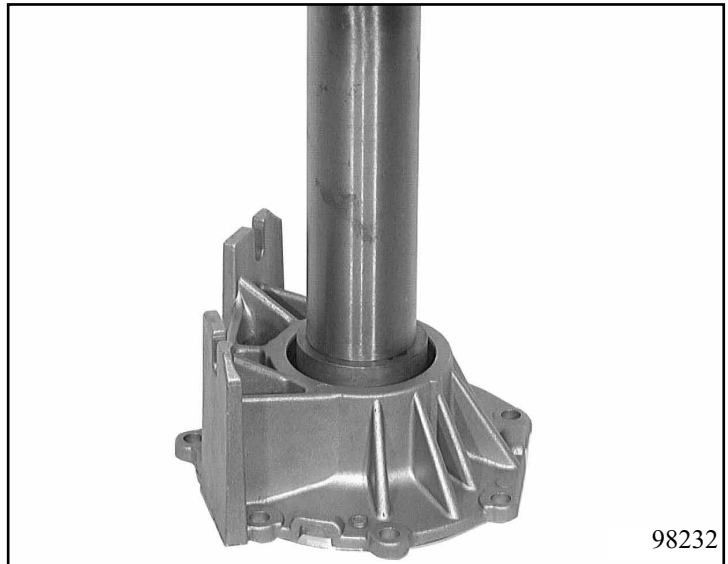

**Important !**  
The bearing inner races are not interchangeable.

## 2.7 Tower

Lift brake D/G and clutch F off the tower.



### 2.7.1 Planetary drive

Remove the angle washer, needle cage and thrust washer from the ring gear. Take off the shaft with the ring gear.

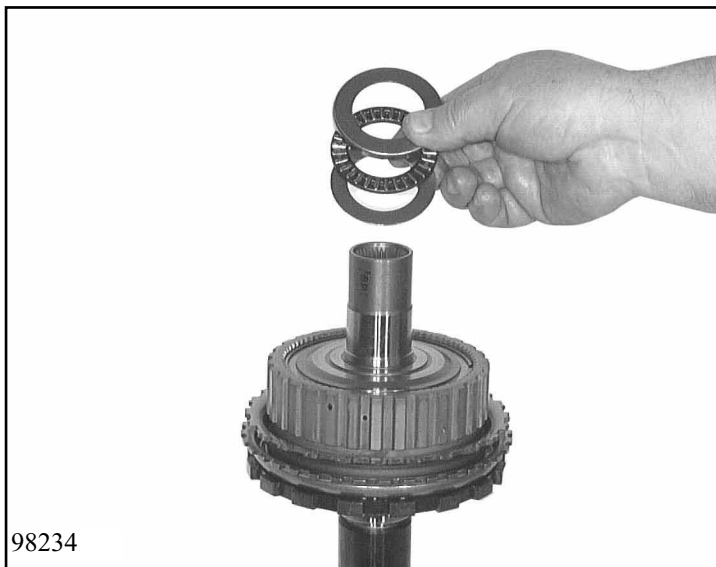

Separate the ring gear from the shaft by removing the snap ring.

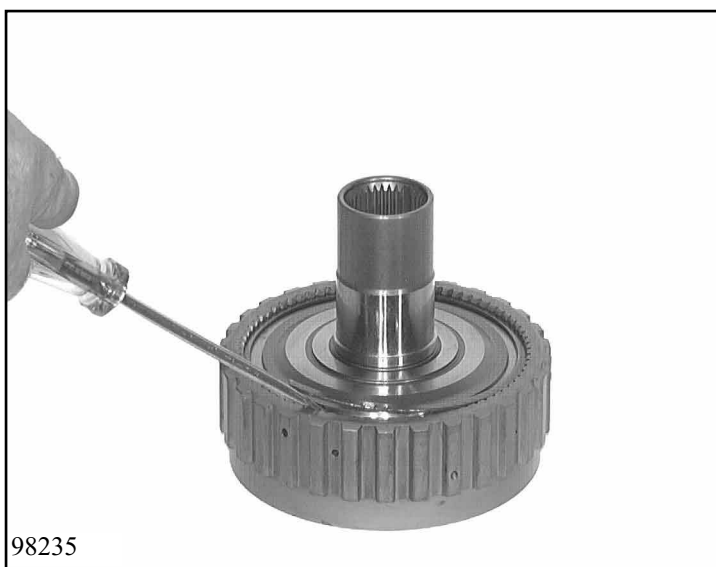

Remove the angle washer, needle cage and thrust washer from the planet carrier.

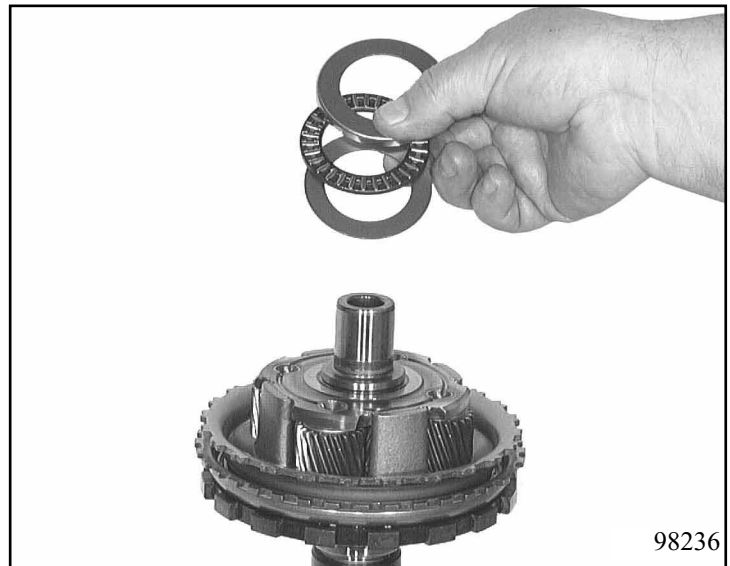

Turn the planet carrier through 180° and remove the snap ring from the shaft with suitable pliers.



Remove the parking lock wheel. Remove the thrust washer, needle cage and angle washer from the sun wheel.

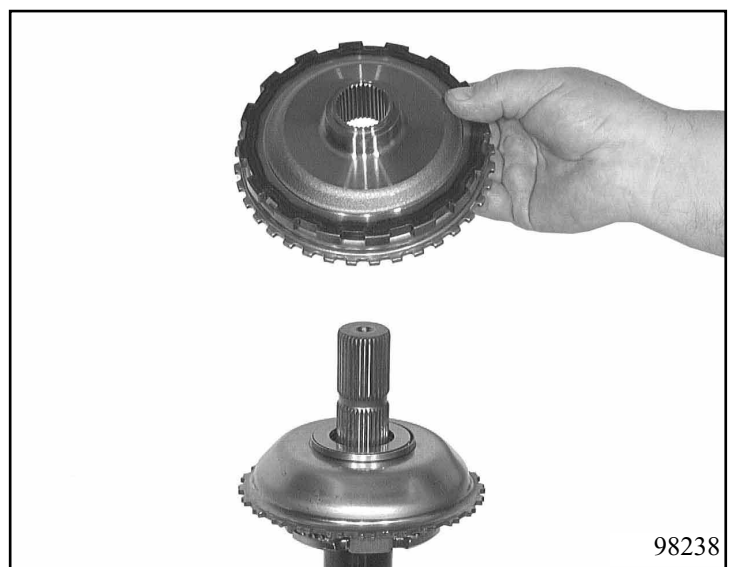



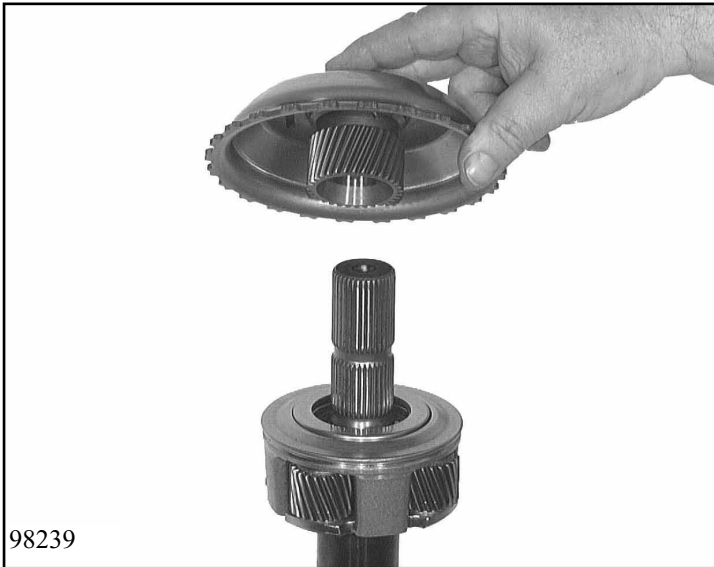

Remove the sun wheel.  
Take the angle washer, needle cage and angle washer off the planet spider. Take the planet carrier out of the holding device.

## 2.7.2 Clutch F

Remove the snap ring from cylinder F and take out the disc pack.



Press the cup spring down with assembly bracket 5x46 002 005 under a mandrel press and remove the split stop ring. Remove the cup spring and the pressure plate.

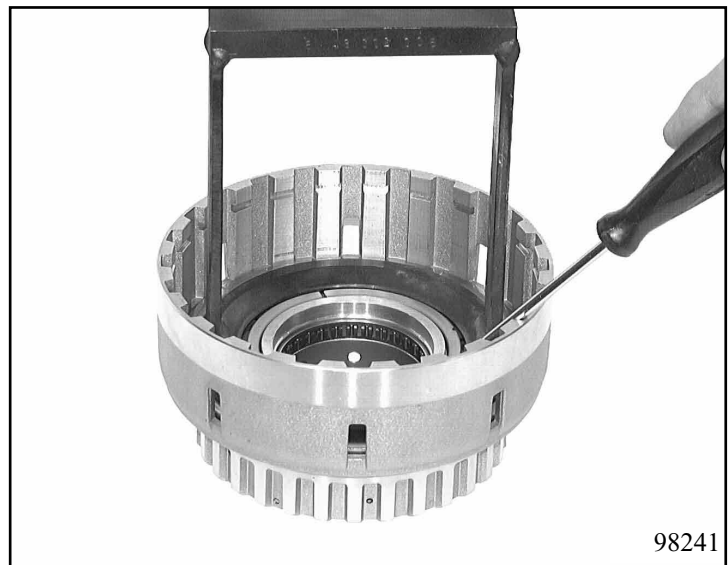

Insert device 5x46 002 088 in cylinder F. Force the piston out with compressed air. Pull the 2 O-rings off the piston.



### 2.7.3 Brake D/G with freewheel, 1st gear

Engage counter support 5X46 000 577 in the holes of the freewheel carrier by means of 3 cylindrical pins.



Turn complete assembly by 180°. Remove snap ring, brake G. Remove the disc assembly. Remove the 2 rectangular-section rings from the carrier.



Press the cup spring down with assembly bracket 5x46 000 576 under a mandrel press. Remove the snap ring with suitable pliers. Remove the assembly bracket. Lift off the thrust washer and the cup spring.



Force out piston G using compressed air in the oil feed hole.  
Pull the 2 O-rings off piston G.

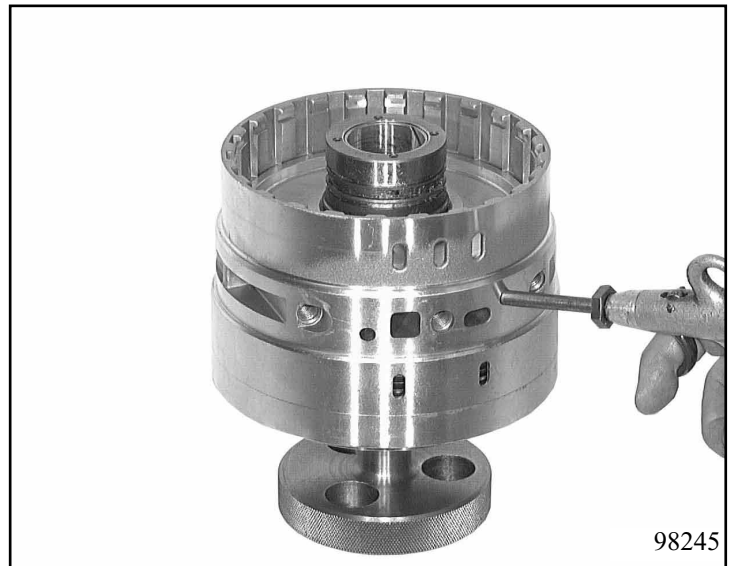

Lift cylinder D/G off the carrier and turn it by 180°.



Remove snap ring, brake D.  
Remove the disc assembly and cup spring.





Force out piston D using compressed air in feed hole.  
Remove the 2 O-rings from the piston.



Remove the 2 O-rings and the fixing washer from the carrier.  
Turn the carrier 180°.  
Disengage the 3 cylindrical pins from the counter support and remove it.



Push the freewheel out of the carrier.



## 2.8 Input assembly

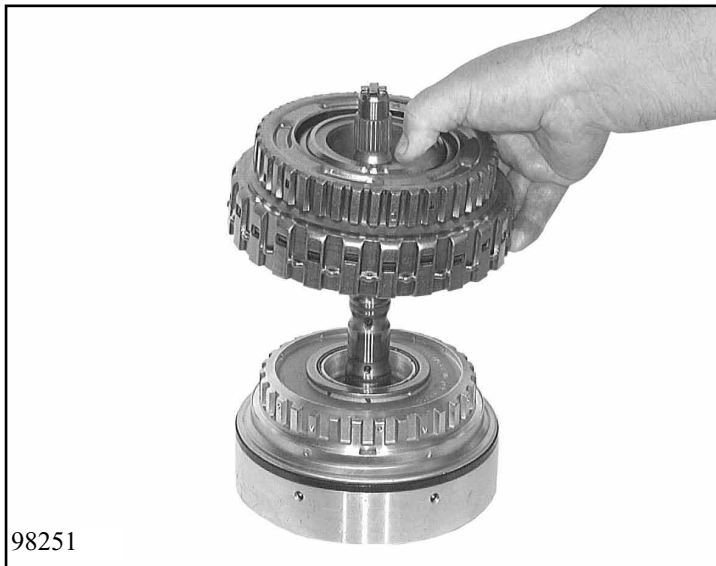

Lift clutch B off A.  
Remove the thrust bearing.

98251

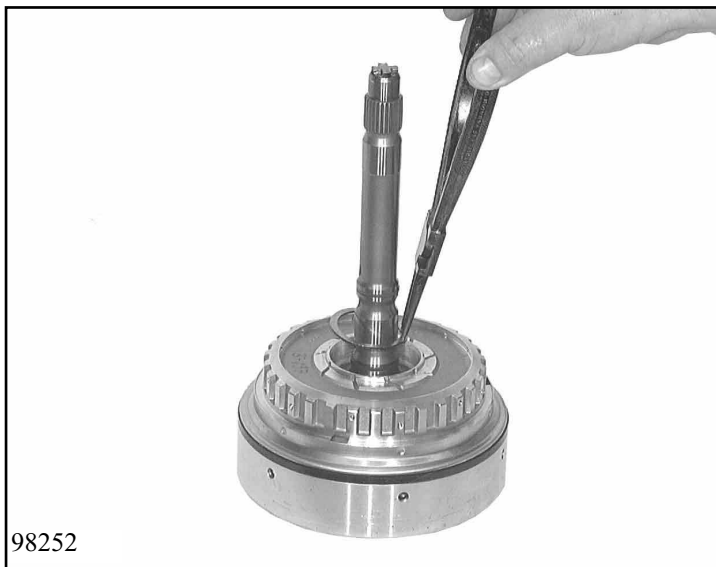

Remove the snap ring from the input shaft using suitable pliers.

98252

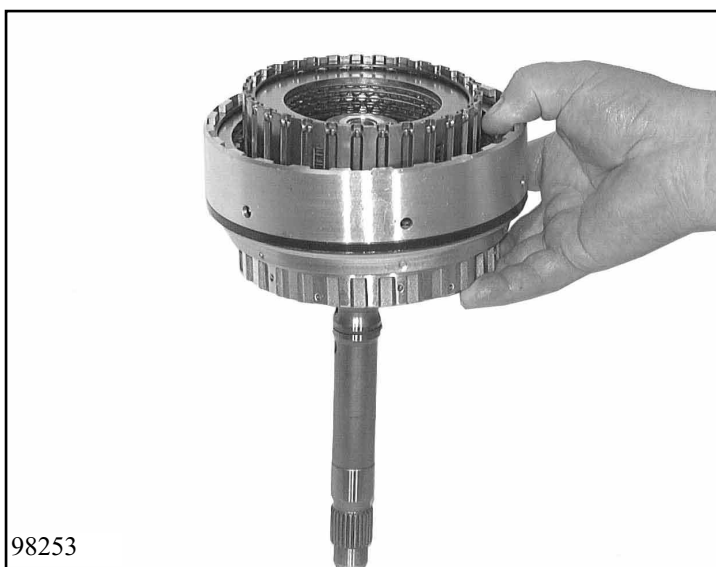

Push clutch E out of clutch A by slight pressure on the input shaft.  
Remove the 2 rectangular-section rings and 1 O-ring from the input shaft.

98253

**Please note:**  
Cylinder A meshes with the input shaft.

### 2.8.1 Clutch E

Insert the input shaft into the holding device 5x46 002 006.  
Remove the snap ring and the disc assembly.



Press down the cup spring with assembly device 5x46 030 167 under a mandrel press and remove the snap ring with a suitable pair of pliers.

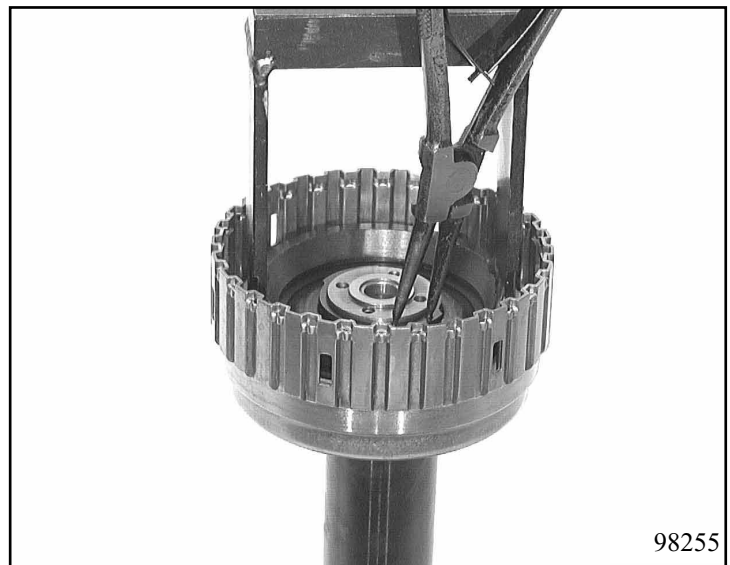

Force out the piston, cup spring and oil dam with compressed air in the oil feed hole.  
Remove the oil dam and cup spring from the piston.  
Pull 1 O-ring off the oil dam and 2 O-rings off the piston.

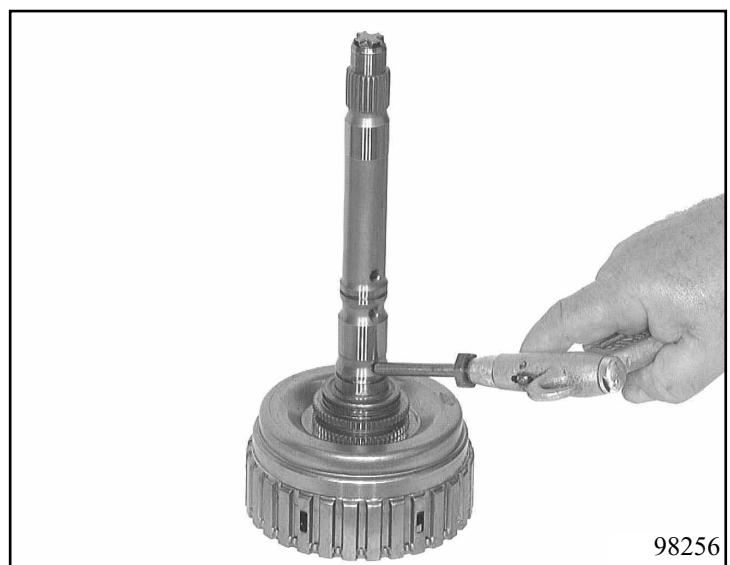



## 2.8.2 Clutch A

Remove the snap ring.  
Remove the disc assembly.



Push down the cup spring with assembly device 5x46 002 004 under a mandrel press, remove the split stop ring and cup spring.

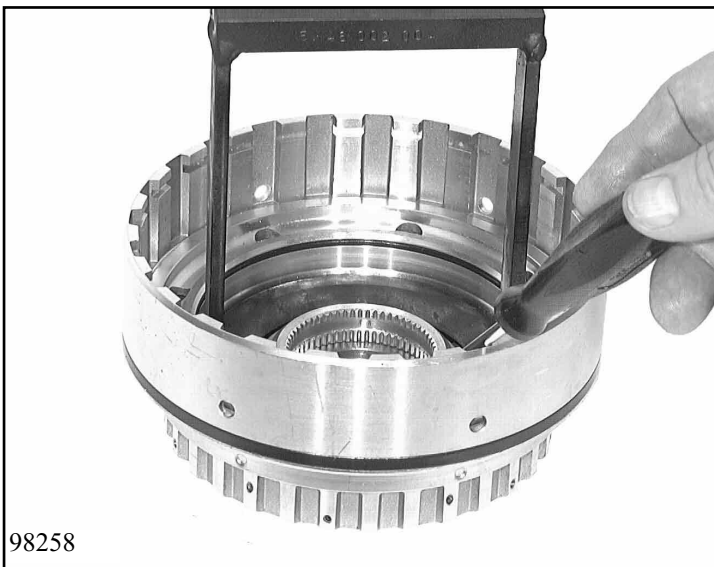

Cover 2 holes with your fingers and force the piston out with compressed air through the 3rd hole.  
Pull the 3 O-rings off piston A.  
Push the ring and O-ring out of hub, cylinder A.  
Pull the O-ring off the ring.



### 2.8.3 Disassembling clutch B.

Remove the snap ring.  
Remove the disc pack.



Push the cup spring down with assembly bracket 5x46 002 005 and remove the split stop ring.  
Remove the cup spring.



Cover one oil feed hole and force the piston out with compressed air through the other.  
Pull the 2 O-rings off the piston.



## 2.9 Oil supply with brake C

### 2.91 Brake C

Remove the snap ring.  
Remove the disc pack.

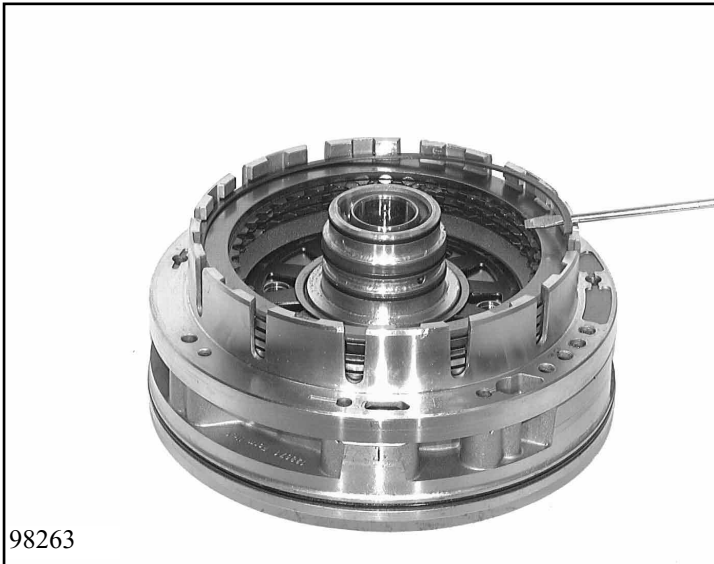

Push the cup spring down with assembly bracket 5X46 000 576. Then remove the split stop ring and the cup spring.

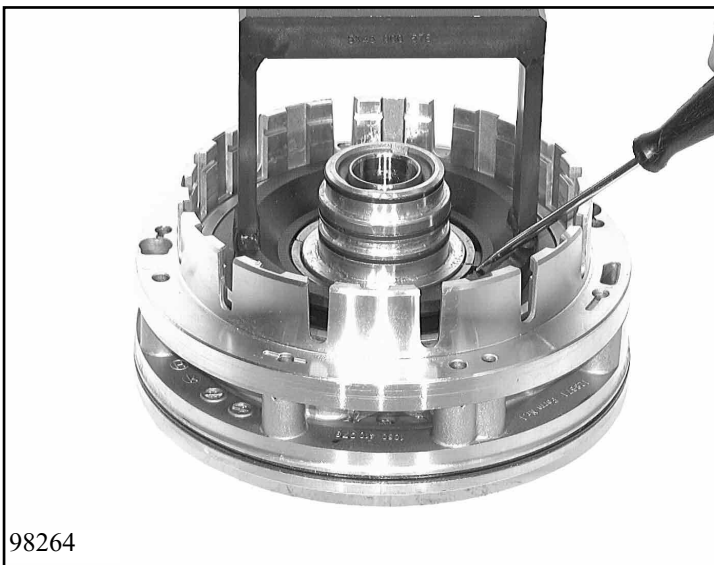

Pull the external disc carrier together with piston C off the oil supply.  
Separate the piston from the external disc carrier.  
Pull the 2 O-rings off piston C.

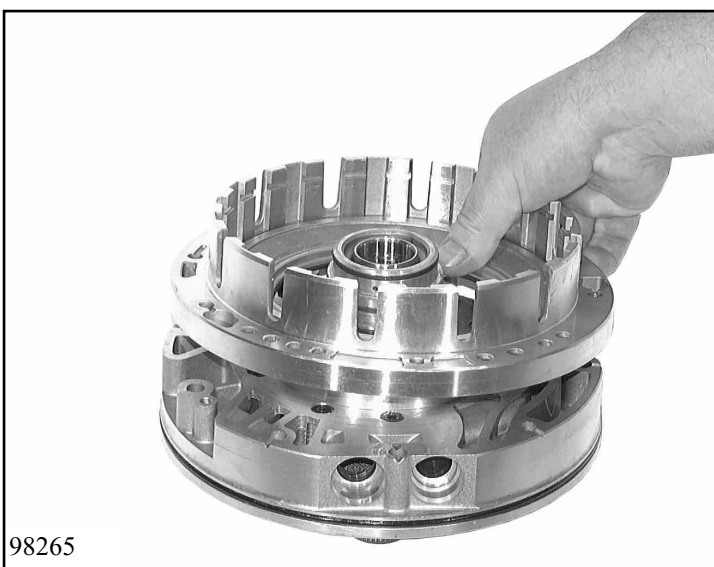

Pull 1 O-ring off the intermediate plate and remove 3 rectangular-section rings from the hub of the stator shaft.



### 2.9.2 Pump

Remove 8 countersunk screws from the outer pitch circle and 1 cheese-head screw and the countersunk screw opposite the latter from the inner pitch circle.

(Wrench size = Torx TX 27)



Screw 2 long-shank screws into two opposite holes in the outer pitch circle and drive the pump out by tapping gently on the screw heads.



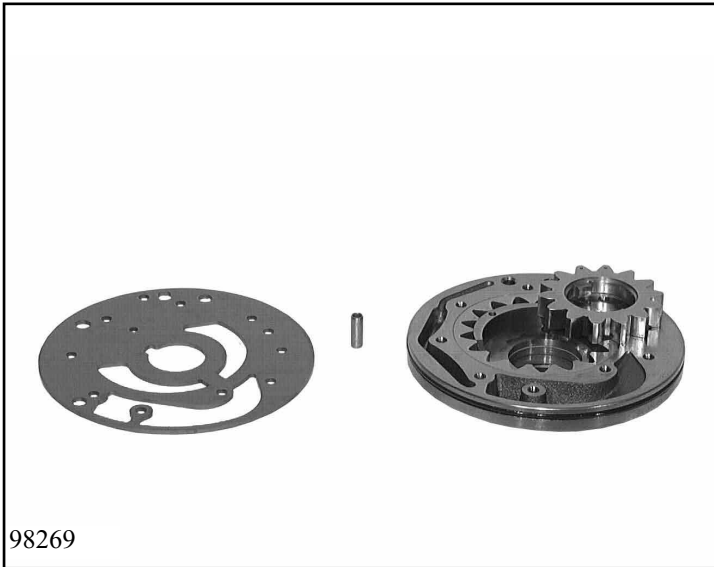

Remove the centering sleeve, intermediate plate, pump wheel and pump ring gear.

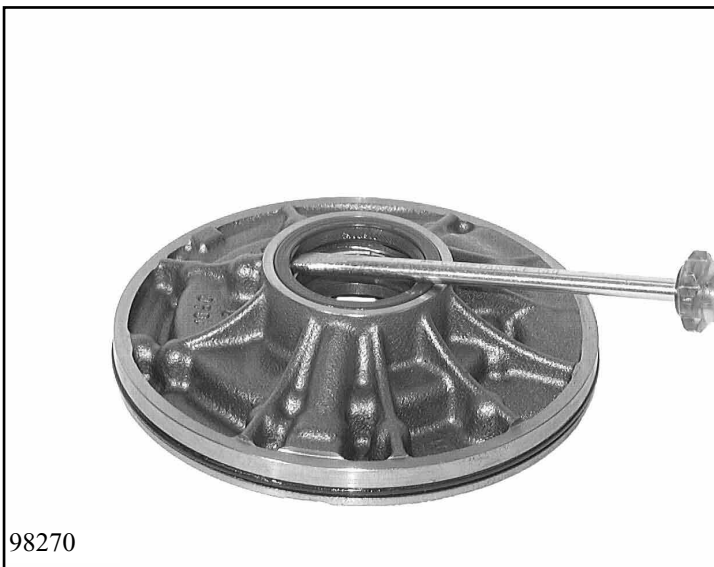

Lever out the shaft seal with a suitable screwdriver and take off the disc. Pull the O-ring off the pump casing.



**Important !**  
 Only undo the 5 screws of the stator shaft if the intermediate plate is damaged. Push them out of the plate with a suitable drift.



### 3. Assembly

#### 3.1 Housing with selector mechanism and parking lock

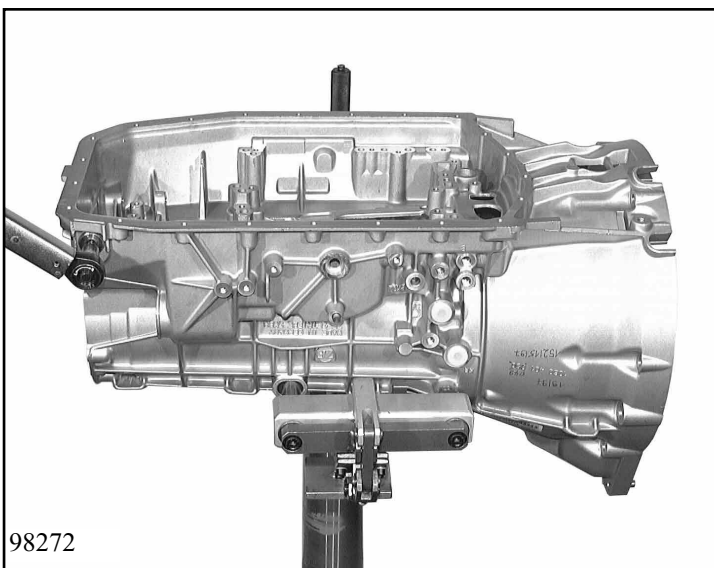
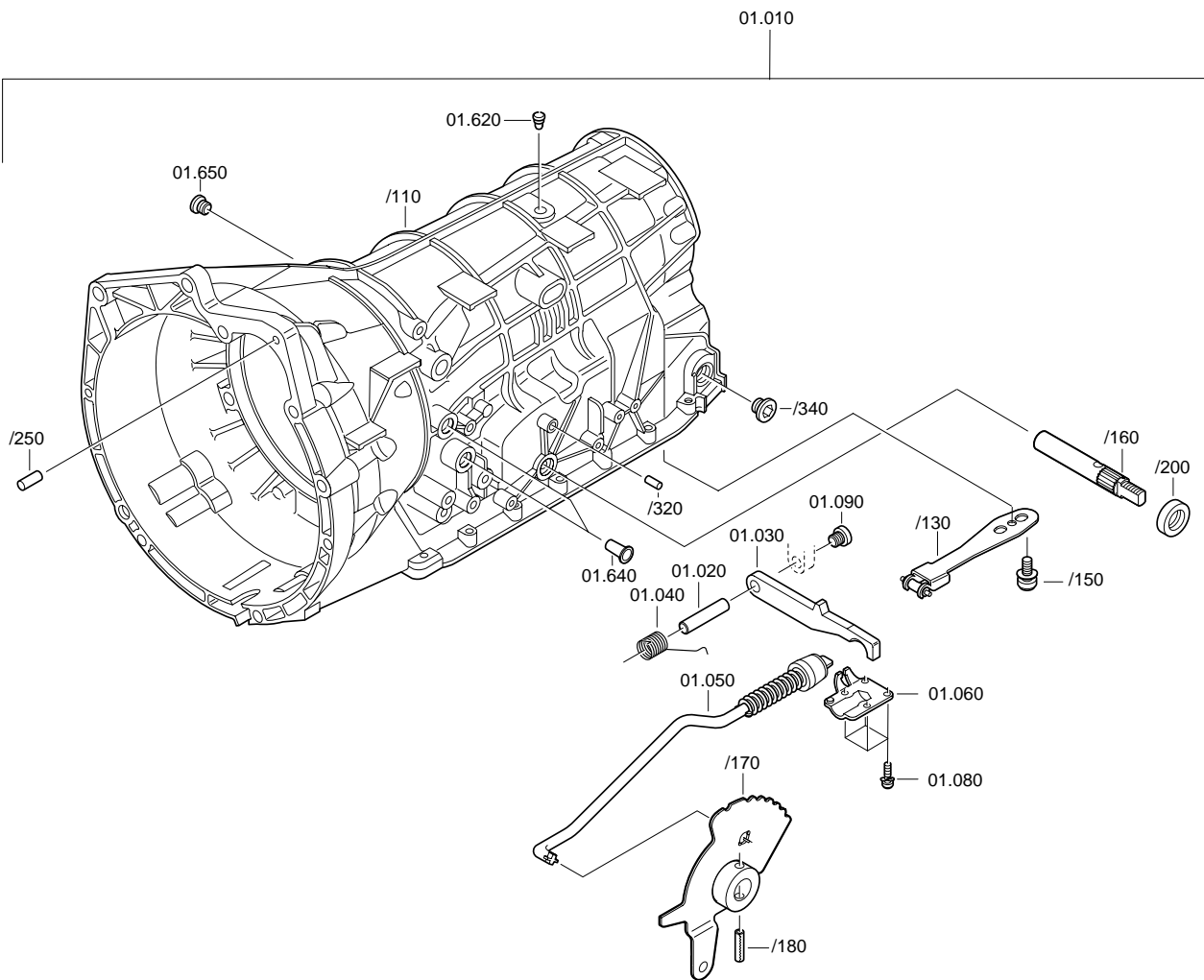

Turn the transmission housing 01.010/110 so that the oil pan faces upwards.

Screw 11 screw plugs 01.650 and oil filler plug 01.010/340 into the transmission housing 01.010/140.

Push 2 plugs 01.640 into transmission housing.

(For tightening torques see 1.5)

#### **Please note:**

In the most recent transmission housings, there is only 1 screw plug 01.650.

If the transmission housing has been changed, drive in new pins 01.010/250 (9.8 + 1.2 mm) and 01.010/320 (5.5 - 0.5 mm), and a new breather 01.620.

**Mounting specification 1060 700 347**

98272

Drive shaft seal 01.010/200 into the transmission housing with drift 5x95 000 038.

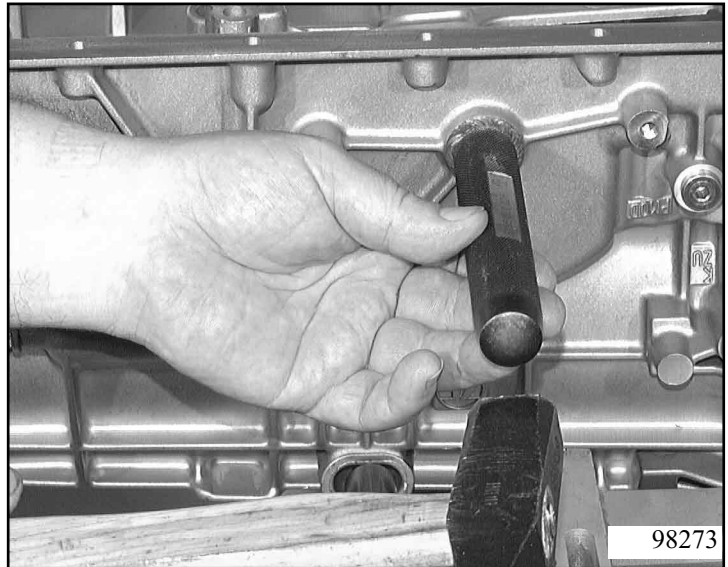

**Important!**

Only if the detent spring is defective  
Screw detent spring 01.010/130 on loosely  
with 2 screws 01.0101/150.

Latch connector rod 01.050 into detent disc 01.010/170 and turn it.

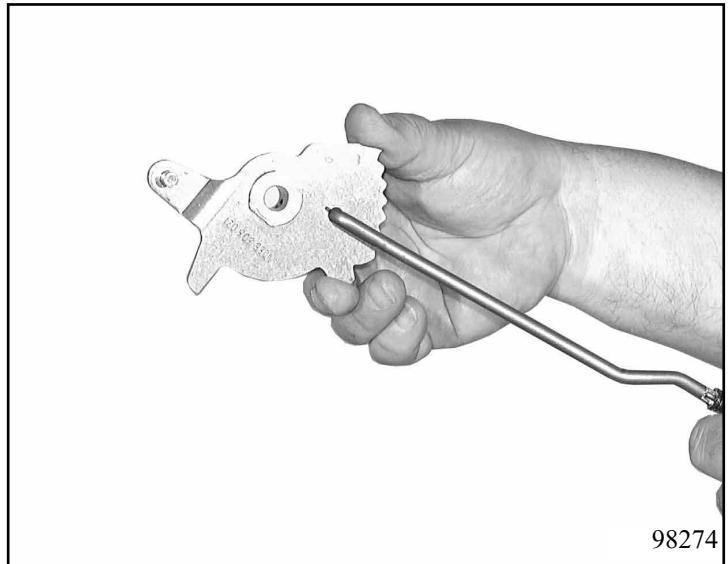

**Important!**

If the transmission housing, detent disc  
or selector shaft have been replaced or  
the detent spring has been detached, the  
detent spring must be readjusted.

Adjustment: **Chapter 1.4.10**

Insert the detent disc and connector rod  
into the transmission housing and push in  
the selector shaft 01.010/160.

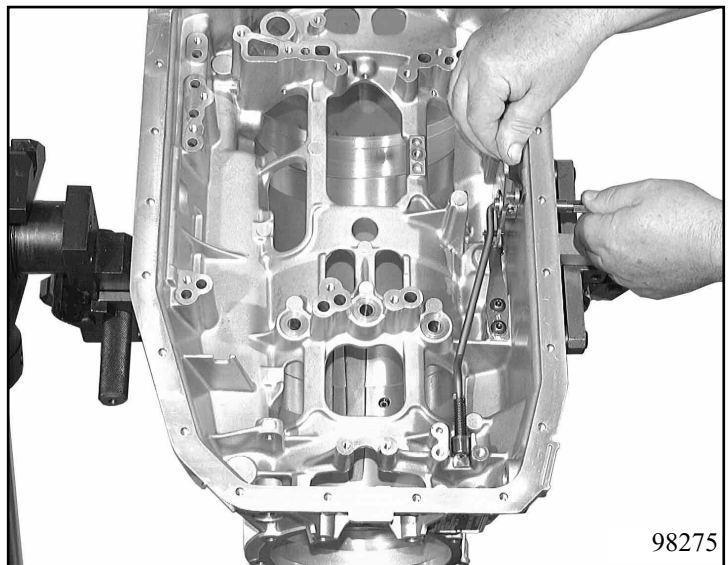



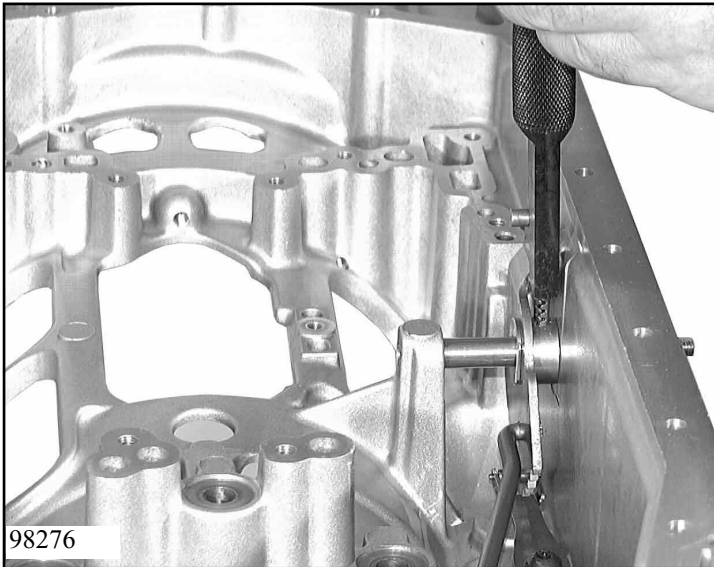

Drive new slotted pin 01.010/180 into the detent disc with driving pin 5x46 000 685.

**Important !**

In position "N", the flat on the selector shaft must face away from the oil pan.

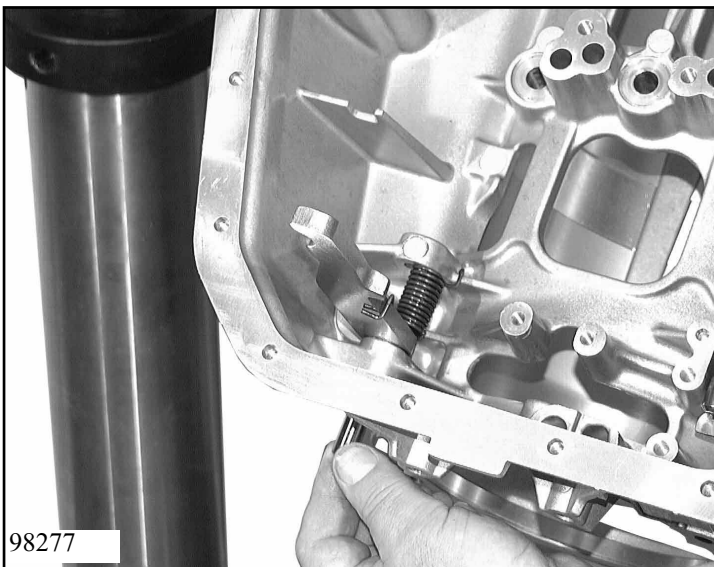

Insert pawl 01.030 and leg spring 01.040 into the transmission housing and fix them by pressing in pin 01.020. Then close the hole with screw plug 01.090.

(For tightening torques, see Chapter 1.5)

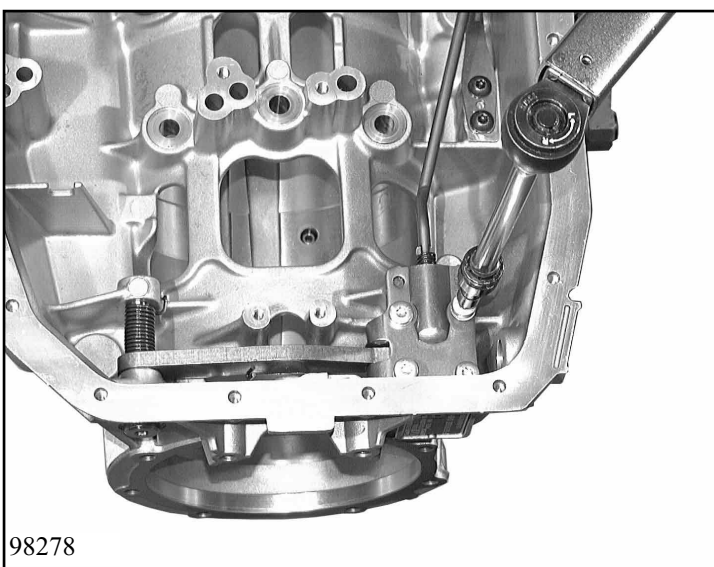

Press down the pawl and fasten guide plate 01.060 with 4 machine screws 01.080.

(For tightening torques, see Chapter 1.5)



### 3.2 Tower

#### 3.2.1 Planetary drive III

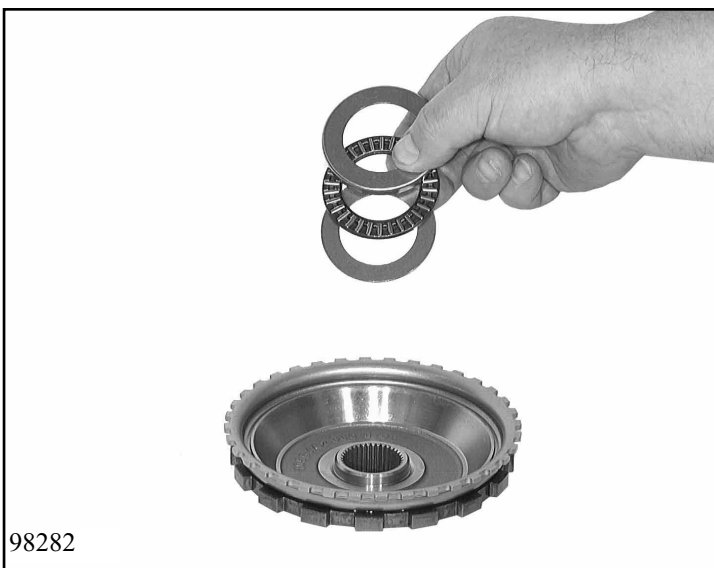
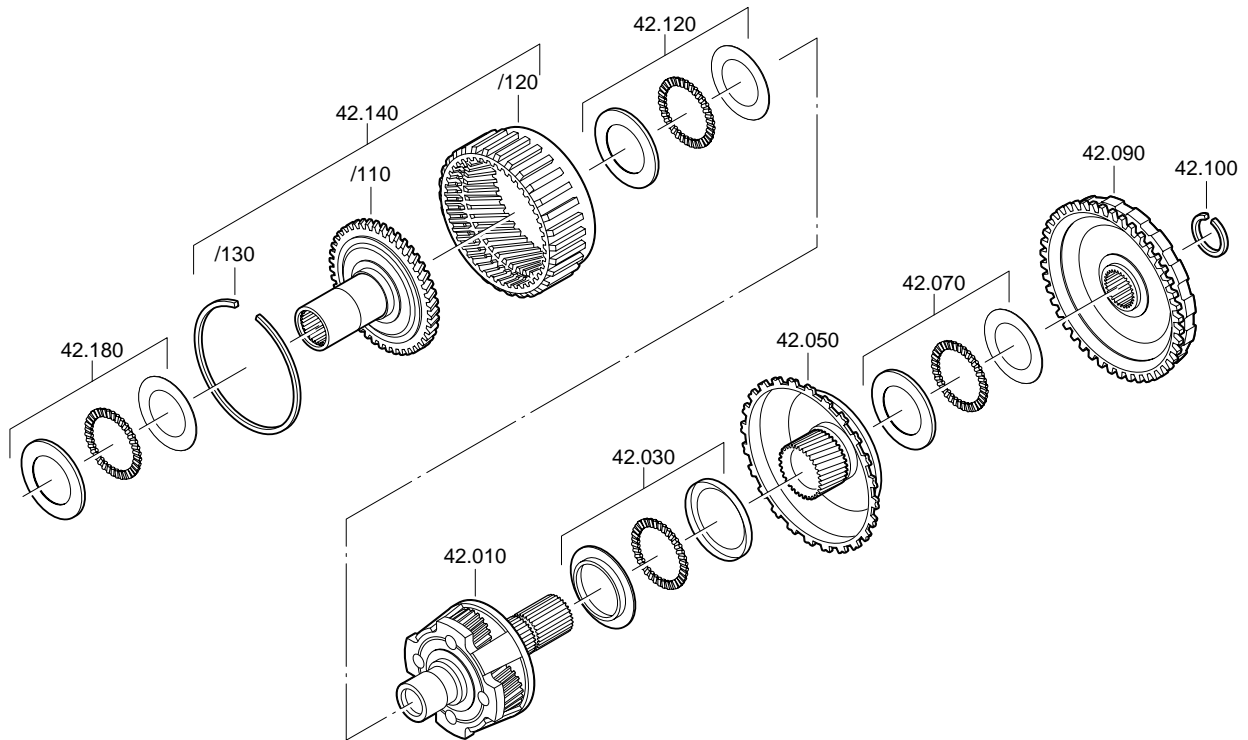

Insert thrust washer 42.070/110, axial needle roller bearing 42.070/120 and angle washer 42.070/130 into parking lock wheel 42.090.

98282

Mount sun wheel 42.050, and insert angle washer 42.030/110 axial needle roller bearing 42.030/120 and angle washer 42.030/130 over sun wheel hub.



Mount planet carrier 42.010.  
Place the unit on supporting fixture 5x46 002 006 and secure with snap ring 42.100.  
Turn the unit by 180°.



**Important !**  
Make sure that the axial bearings remain centered.

Insert the ring gear carrier 42.140/110 into the ring gear 42.140/120 and secure with snap ring 42.140/130.

Place thrust washer 42.180/110, axial needle roller bearing 42.180/120 and angle washer 42.180/130 on the ring gear unit.

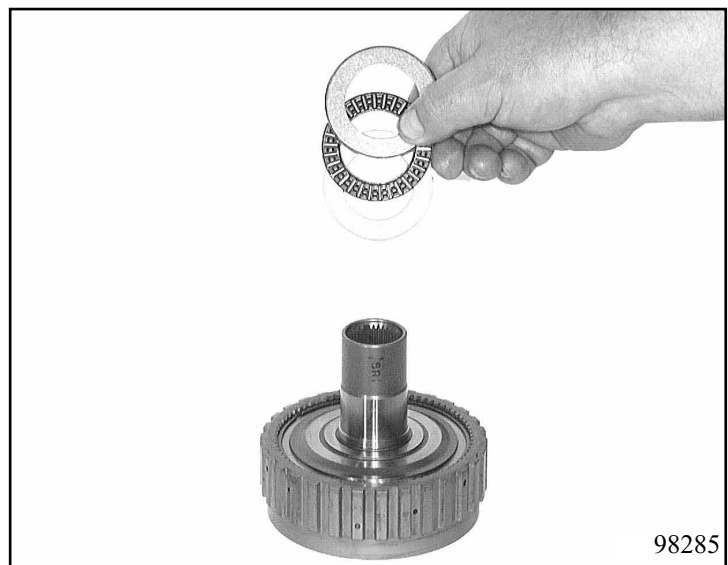

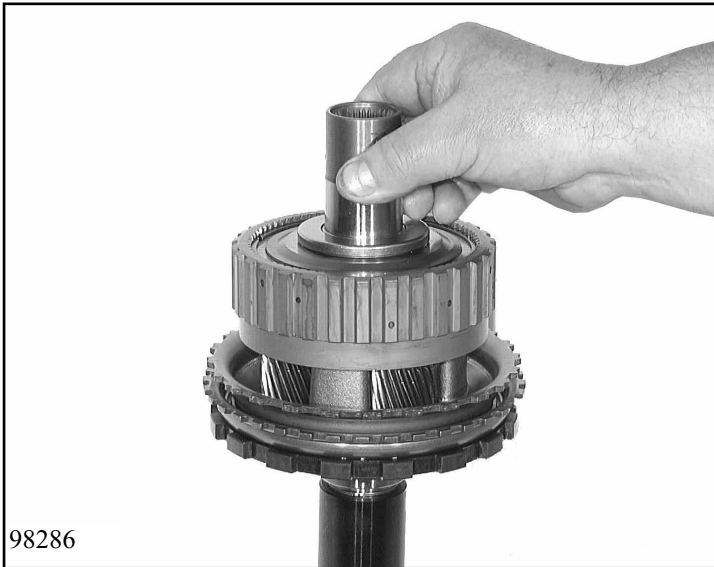

Place thrust washer 42.120/110, axial needle roller bearing 42.120/120 and angle washer 42.120/130 on planet carrier and mount the complete ring gear unit.

### 3.2.2 Clutch F

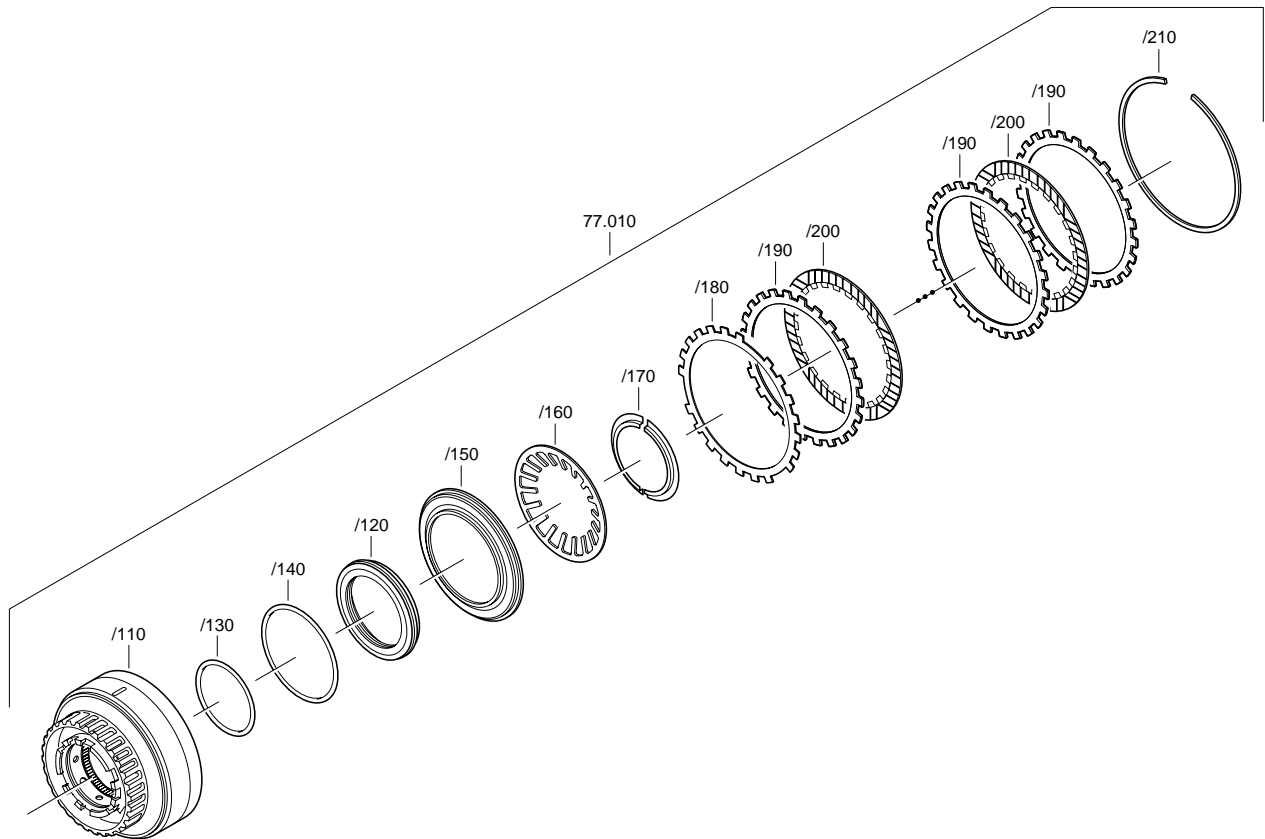

Press 2 new O-rings 77.010/130 and 77.010/140 onto piston 77.010/120 and press this into cylinder F 77.010/110. Place pressure plate 77.010/150 on piston.

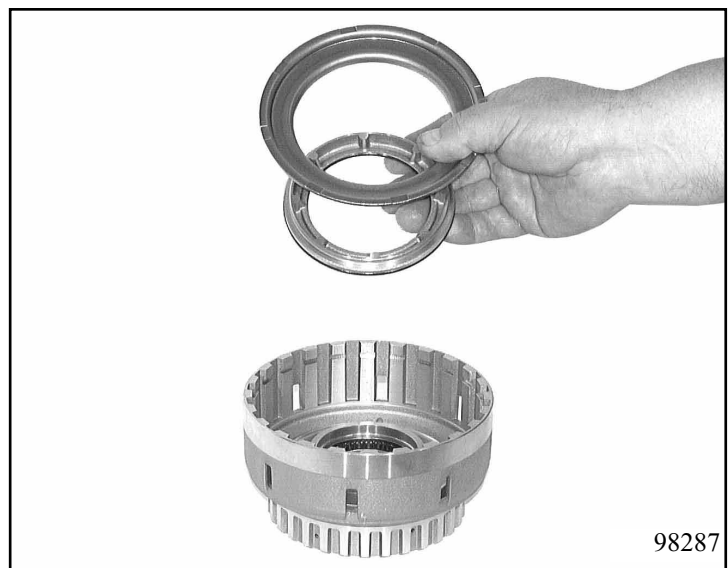

98287

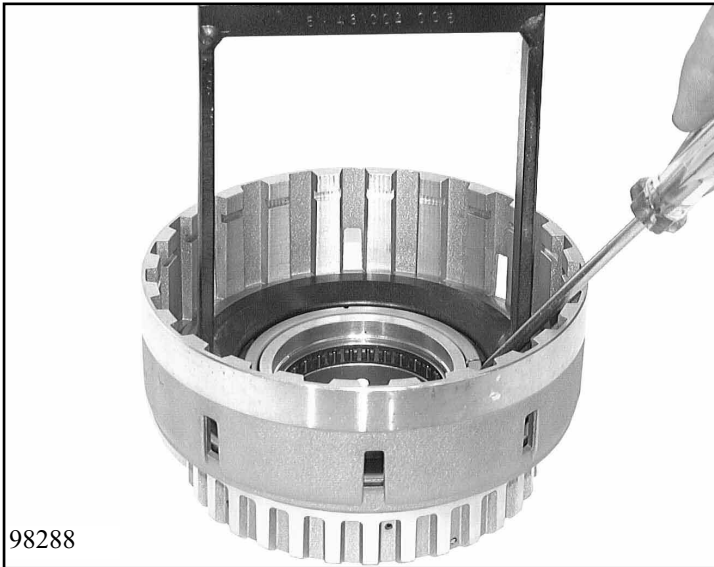

98288

Insert cup spring 77.010/160, press down with assembly bracket 5x46 002 005 on a mandrel press and mount the split stop ring 77.010/170.

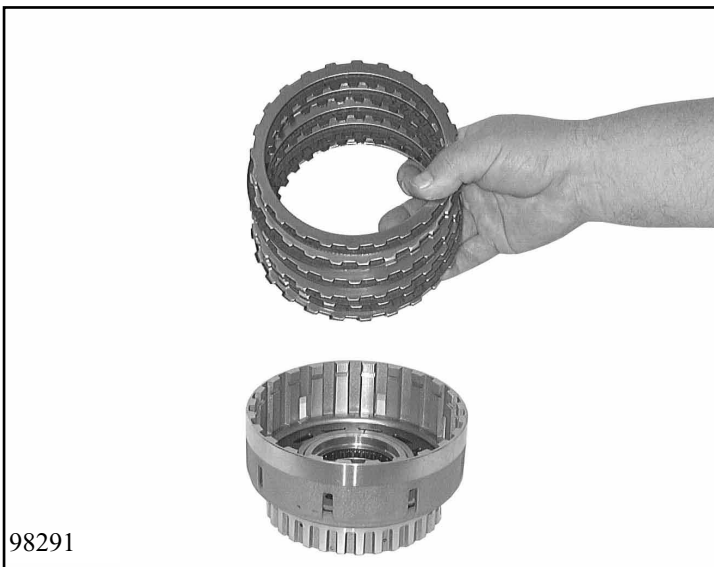

98291

Insert the complete disc assembly, starting with the spring disc 77.010/180. Then insert alternate steel discs 77.010/190 and lined discs 77.010/200. Secure upper steel disc with snap ring 77.010/210.

**Important. !**  
For adjustment see **Chapter 1.4.1**



98292

Place clutch F on the planetary drive, turning it backwards and forwards as you do so until the teeth on the lined discs and the ring gear mesh fully.

Check by looking through the cutouts in the cylinder. The final disc must not have been pushed upwards by the lining discs. The gap at the top must be larger than that at the bottom.

### 3.2.3 Brake DG with freewheel, 1st gear

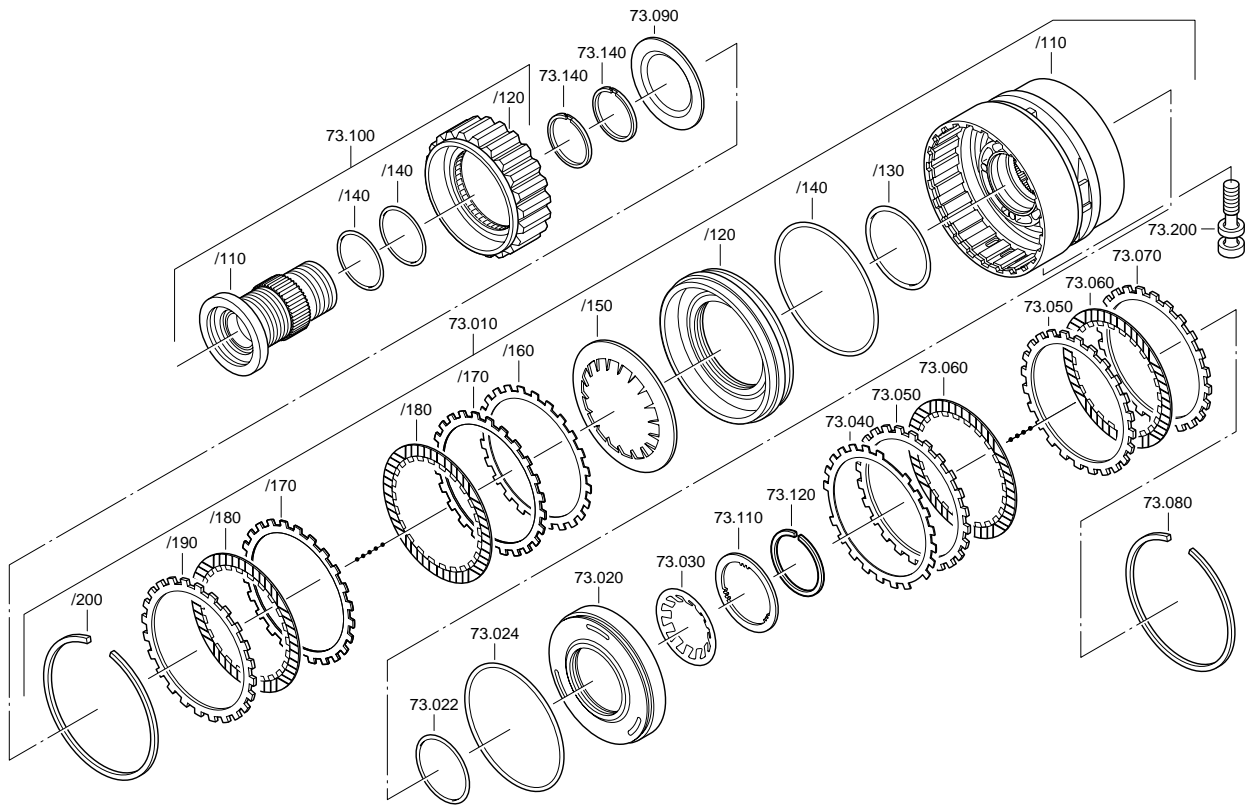

First determine the release clearance of the brakes DG.  
 For that mount 2 O-rings 73.010/130, /140 on piston D 73.010/120.  
 Mount 2 O-rings 73.022, 73.024 on piston G 73.020. Mount both pistons in cylinder DG 73.010/110.

#### **Important !**

For adjustment see **Chapter 1.4.2, 1.4.3**  
 To avoid distortion of the measurements, the pistons must be fully in contact. If necessary, press them home with a suitable drift.



98293



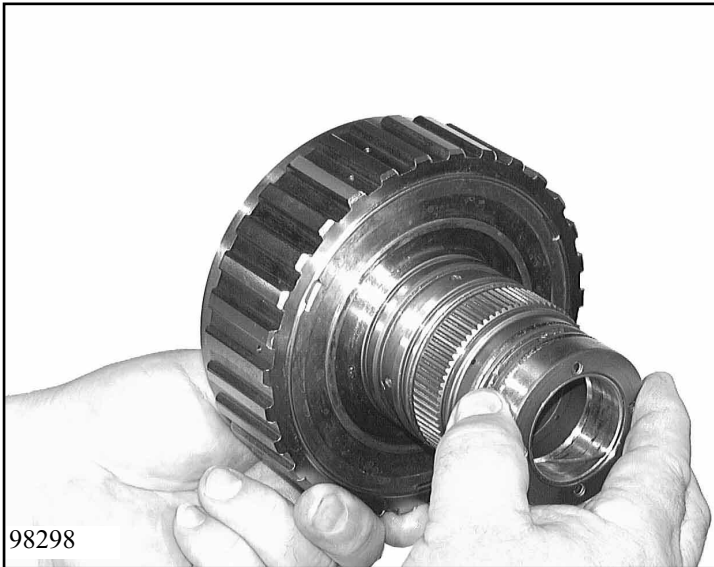

Hold the freewheel 73.100/120 firmly and press the carrier (internal sprag race) 73.100/110 into it, turning the carrier clockwise as you do so.

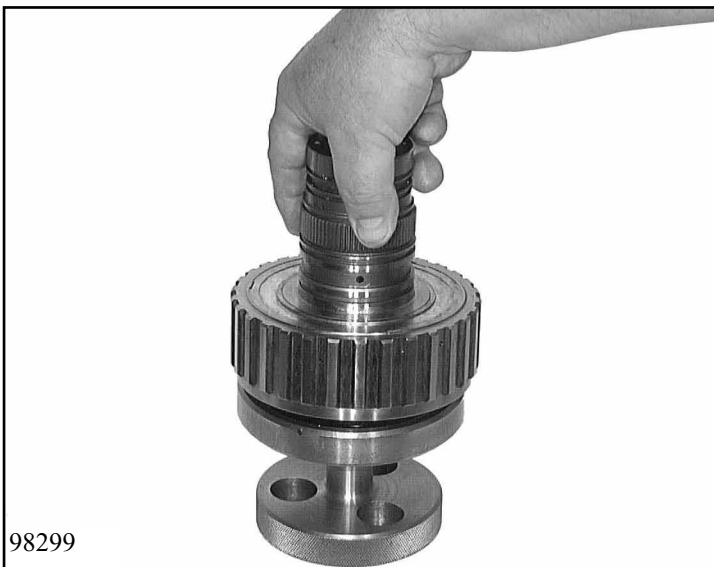

Place the complete unit on the counter support 5x46 000 577 and engage the 3 cylindrical pins of the support in the freewheel by turning. Pull on 2 O-rings 73.100/140.

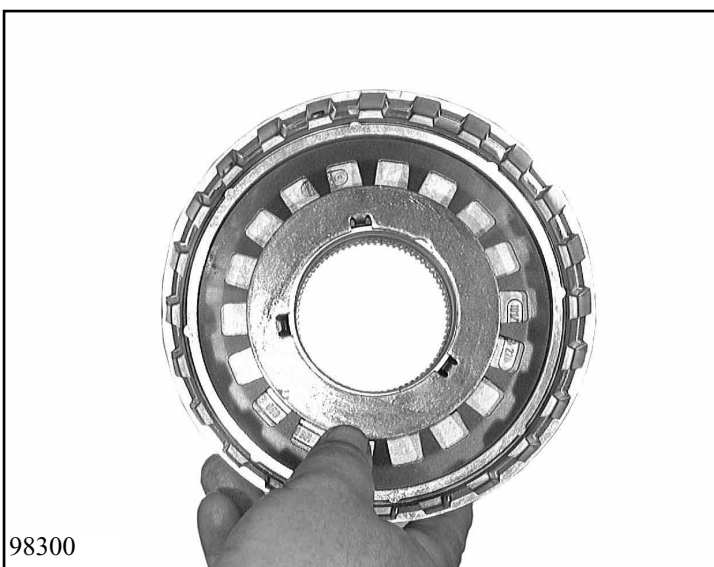

Insert cup spring 73.010/150 and fixing washer 73.090 into cylinder DG.

Place cylinder DG on a suitable surface and press the complete carrier into the cylinder until it meets the stop. Turn the unit by 180°.

**Caution !**

Take care that the assembly does not fall apart!



Insert cup spring 73.030 on side G of the cylinder DG.  
Mount thrust washer 73.110.

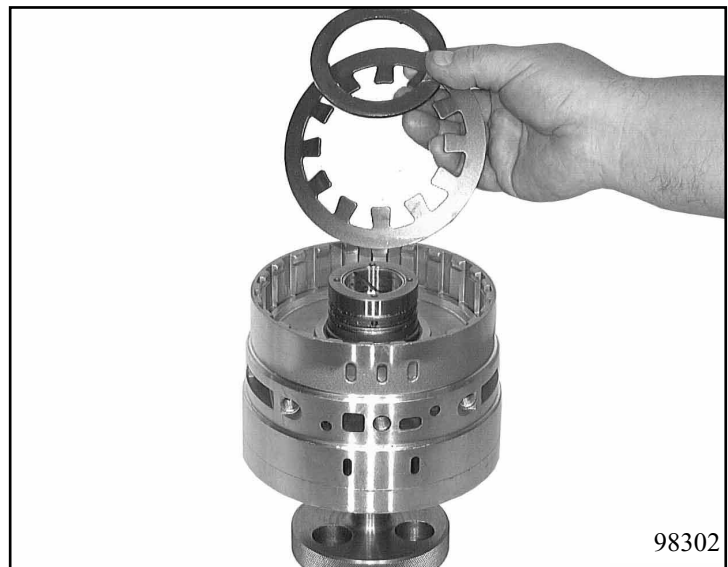

Place snap ring 73.120 on the taper of assembly device 5x46 000 576 and press it down slightly with a pressure piece. Place taper on the hub, place the pressure piece over it and insert the bracket of the assembly device into the cylinder. Press down the complete unit on a mandrel press.

**Important !**

The teeth on the thrust washer must mesh with the teeth on the carrier.



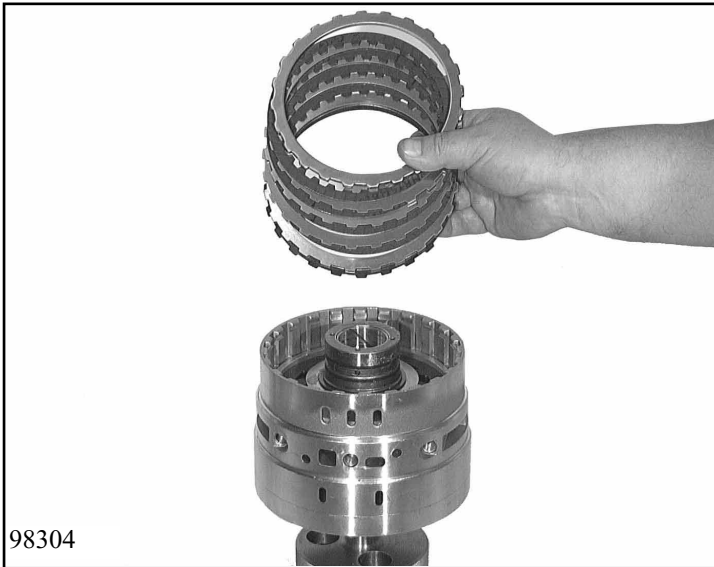

98304

Mount 2 rectangular-section rings 73.140 on the carrier.

Insert disc pack G, starting with spring disc 73.040, followed alternately by steel discs 73.050 and lined discs 73.060.

Insert final disc 73.070 and secure with snap ring 73.080.



98305

Turn the complete unit and remove the counter support.

Insert disc assembly D, starting with spring disc 73.010/160, followed alternately by steel discs 73.010/170 and lined discs 73.010/180.

Insert end disc 73.010/190 and secure with snap ring 73.010/200.

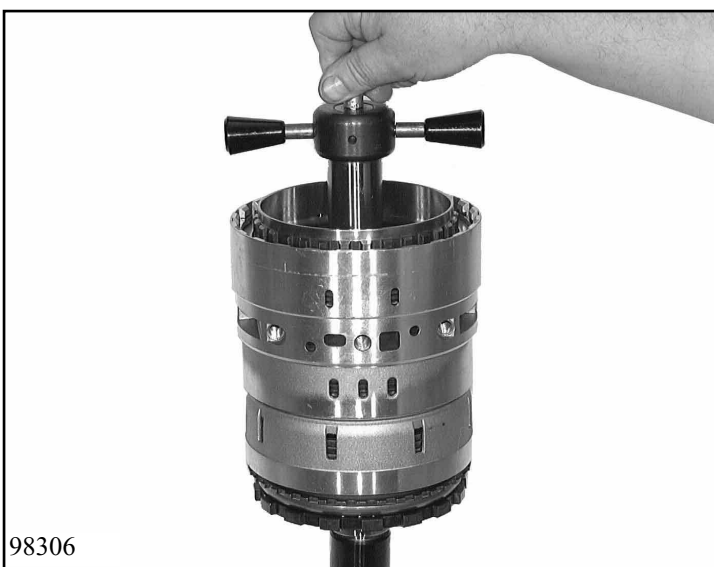

98306

Place brake DG with 1st gear freewheel on clutch F and move backwards and forwards until the teeth on the lined discs mesh fully with the interior disc carrier. Insert lifting device 5x46 000 545 into the planet carrier of the complete planetary drive (tower). Press down the lever in the centre.

**Please note:**

This is not possible if brake DG has been mounted incorrectly on F.

Turn the transmission housing by 90°. Insert the tower into the transmission housing, making sure that the 3 holes are aligned with one another.

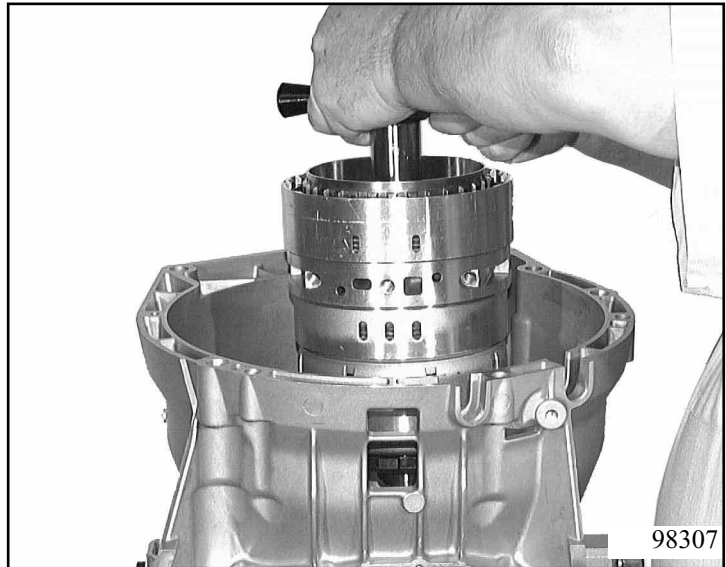

**Important !**

The transmission housing must remain in this position.

Fasten the tower securely with 3 machine screws 73.200.  
Turn the transmission by 180°.

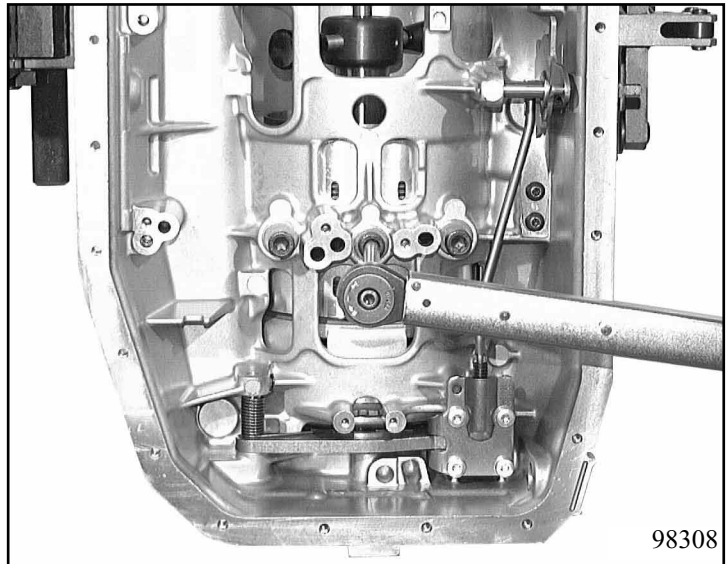

**Important !**

Screw tightening instructions see **Chapter 1.3.1**

The lifting device must remain attached.

### 3.3 Output assembly

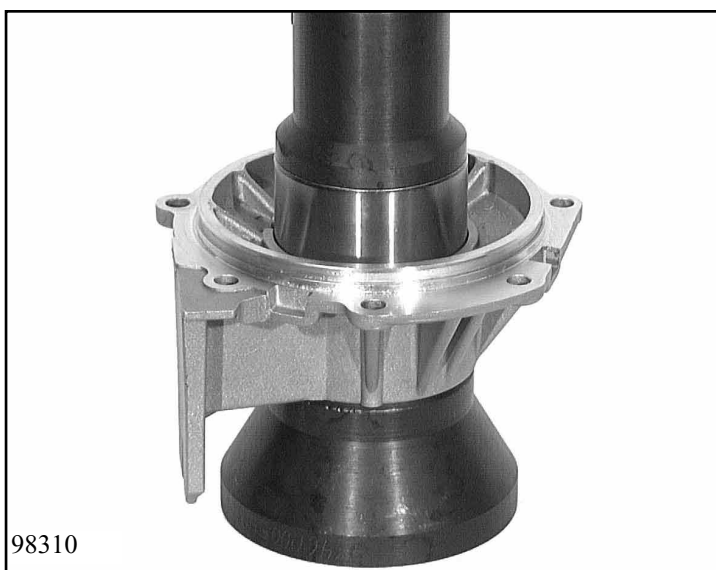
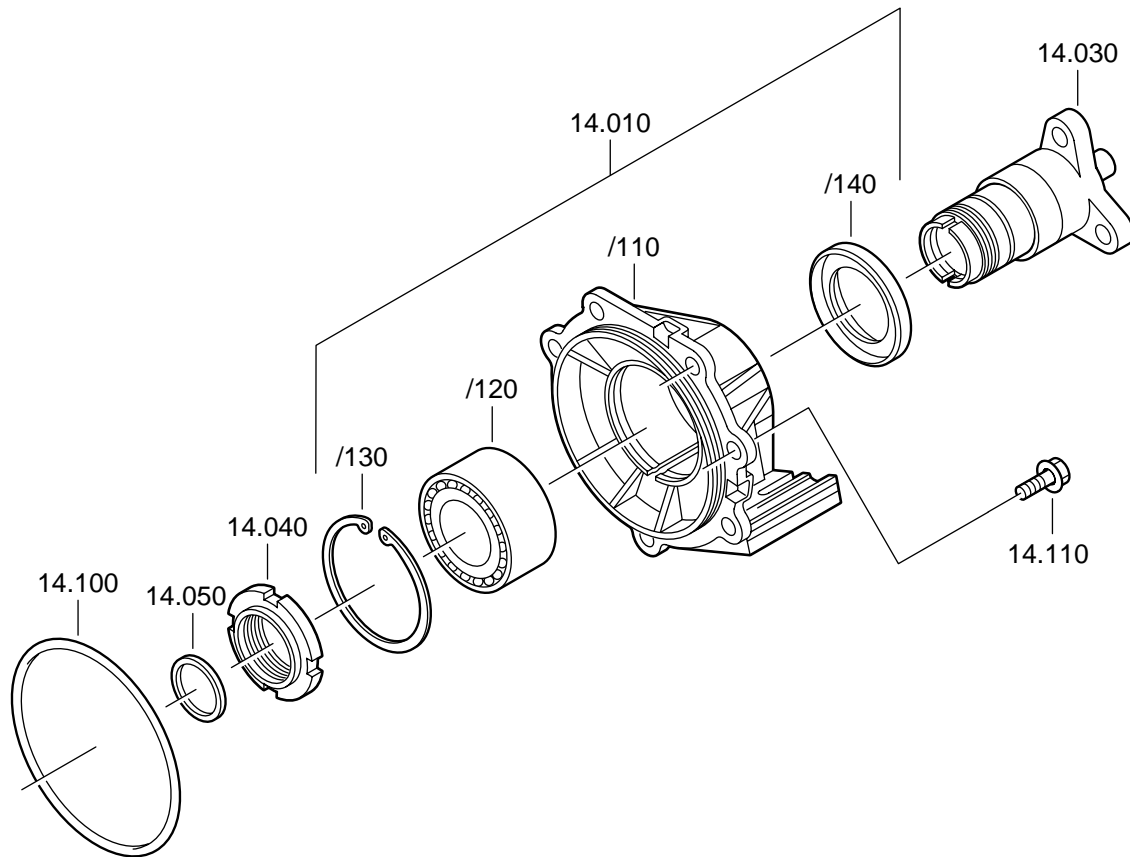

98310

Place extension 14.010/110 on the supporting surface of the press-in device 5x46 000 760.

Place ball bearing 14.010/120 on the press-in pin of the tool. Press it into the extension on the mandrel press and secure with snap ring 14.010/130.

#### **Important !**

The two inner races of the bearings must not be mixed up or turned relative to one another. The cutouts at the edges must face one another.

Turn the extension around and mount shaft seal 14.010/140 under the mandrel press using press-in pin 5x46 000 761. Pull on O-ring 14.100.

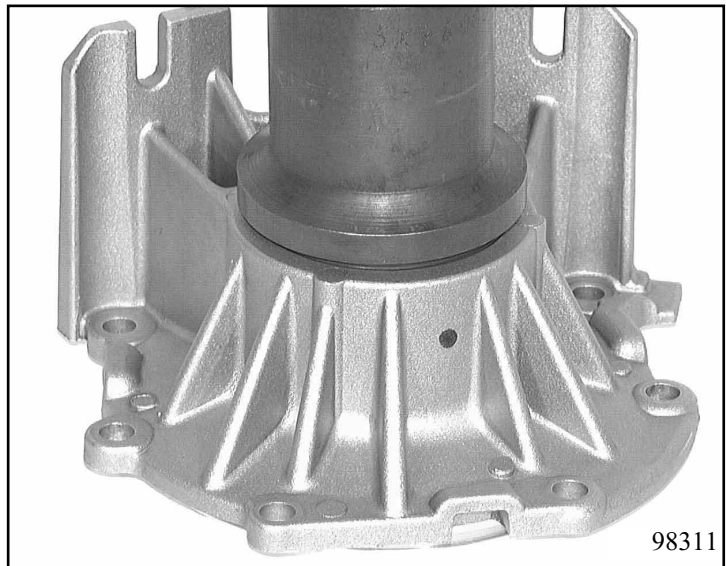

Mount the extension on holding device 5x46 002 089. Insert output flange 14.030 into the double bearing and press it in on the mandrel press using a suitable mandrel.

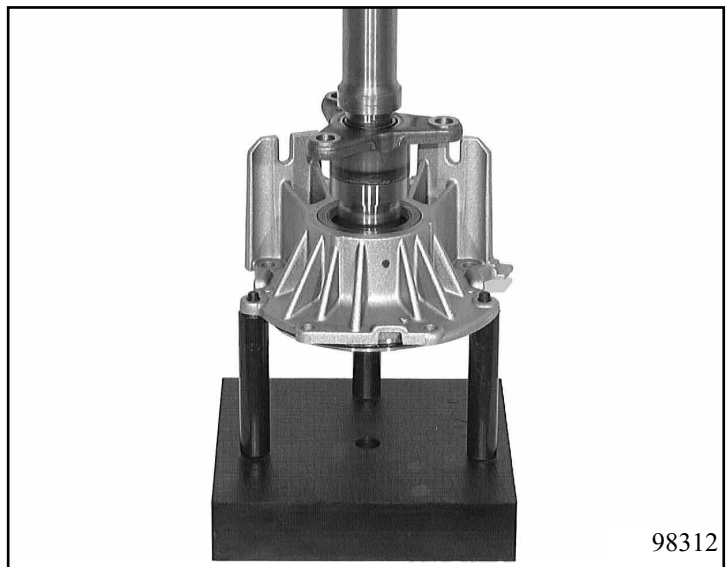

#### Work with a vice:

Place the output flange on holding device 5x46 000 946.

Screw slotted nut 14.040 onto the output flange and tighten with wrench 5x46 000 541.

Secure the slotted nut and secure at two points on the circumference.

(For tightening torques, see Chapter 1.5)



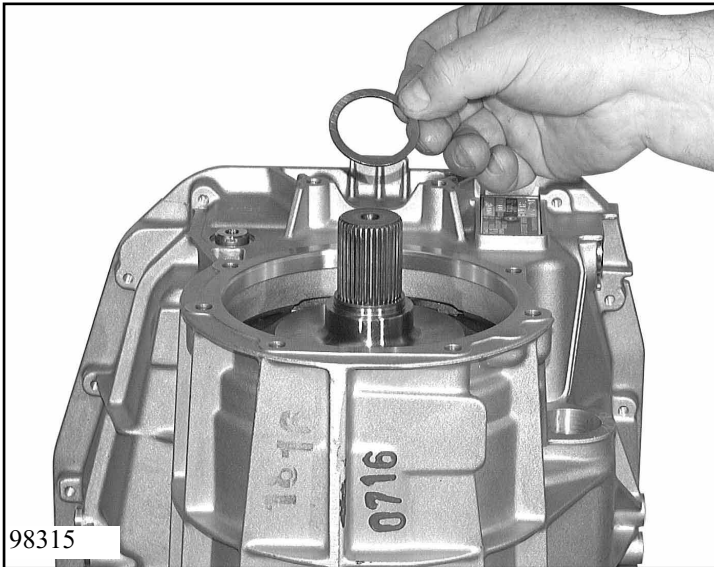

Place disc 14.050 on the parking lock wheel in the transmission housing.

**Please note:**  
For adjustment, see **Chapter 1.4.8**

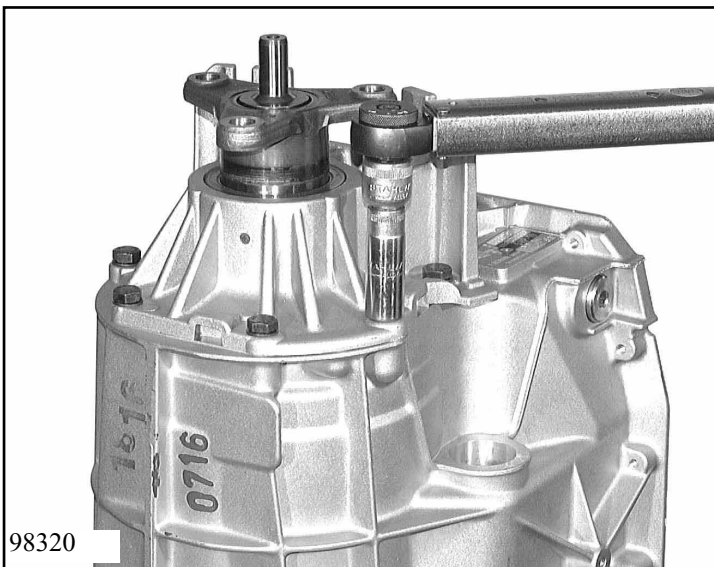

Place output assembly on and fasten with 7 hexagon screws 14.110.

(For tightening torques, see Chapter 1.5)





### 3.4 Planetary drives I and II

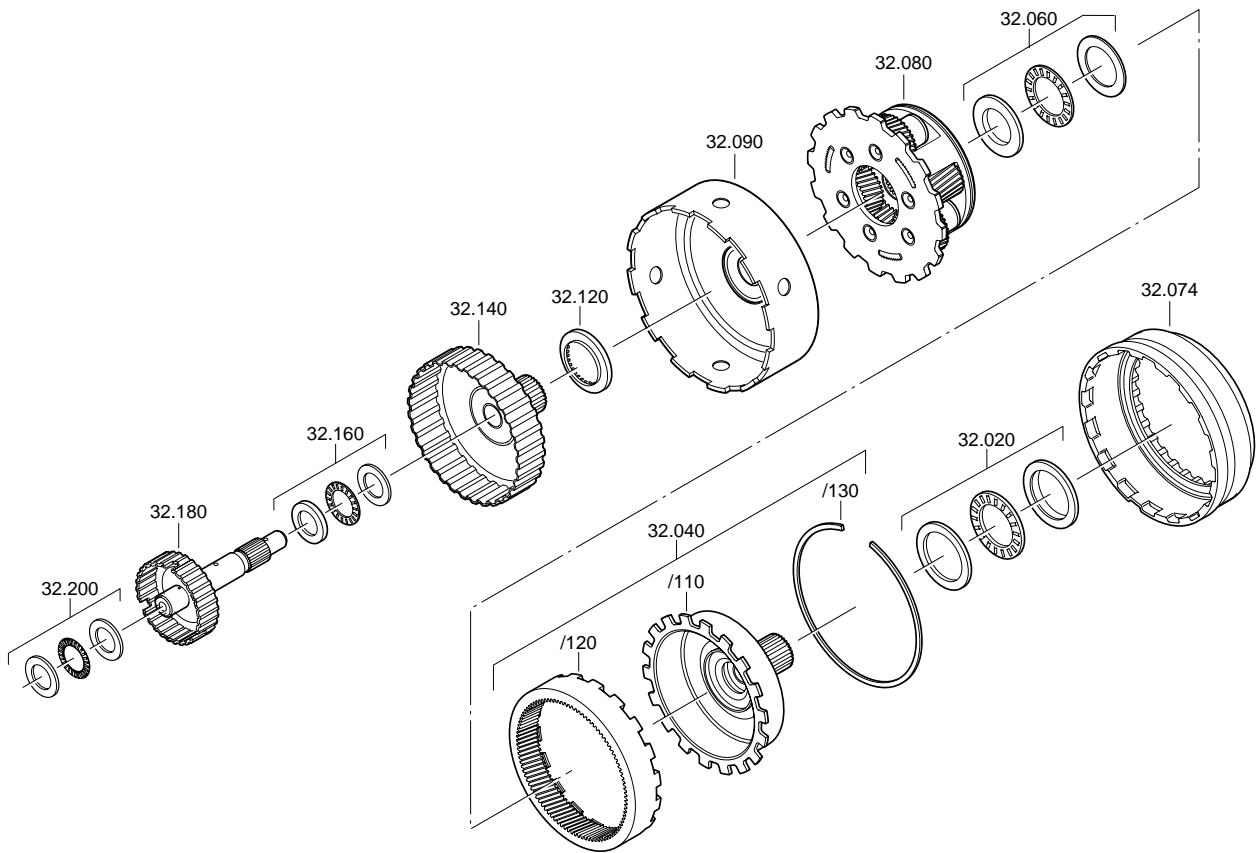

Turn the transmission by 180 ° and pull out lifting device 5x46 000 545 using the central handle.  
Place spider clutch bell 32.074 on the freewheel.

98321

Insert shaft 32.040/110 into ring gear 32.040/120 and secure with snap ring 32.040/130.



Insert angle washer 32.020/110, axial needle roller bearing 32.020/120 and thrust washer 32.020/130.



Insert the output shaft and ring gear into the transmission housing.



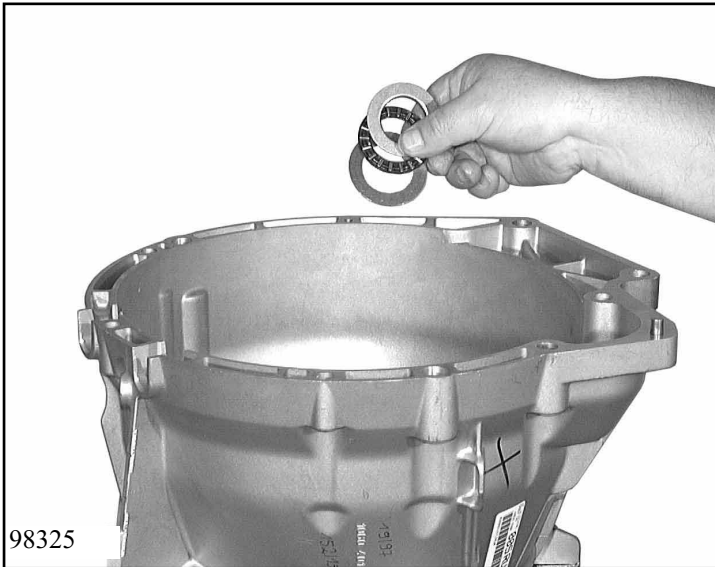

Insert thrust washer 32.060/110, axial needle roller cage 32.060/120 and angle washer 32.060/130.



Insert planet carrier 32.080 into the transmission housing.



Insert sun wheel with cup 32.090 into the planet carrier.

Insert axial needle roller bearing 32.120 into the cup.



Insert sun wheel shaft 32.140 and check operation.  
If assembly has been carried out correctly, the cup should turn in the opposite direction to the sun wheel shaft.



Slide angle washer 32.160/110, axial needle cage 32.160/120 and thrust washer 32.160/130 over the end of the intermediate shaft 32.180 and insert the intermediate shaft.

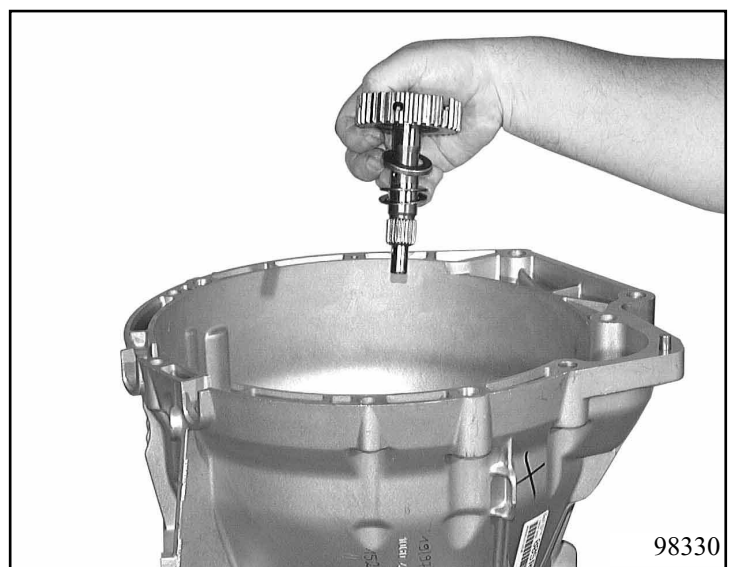

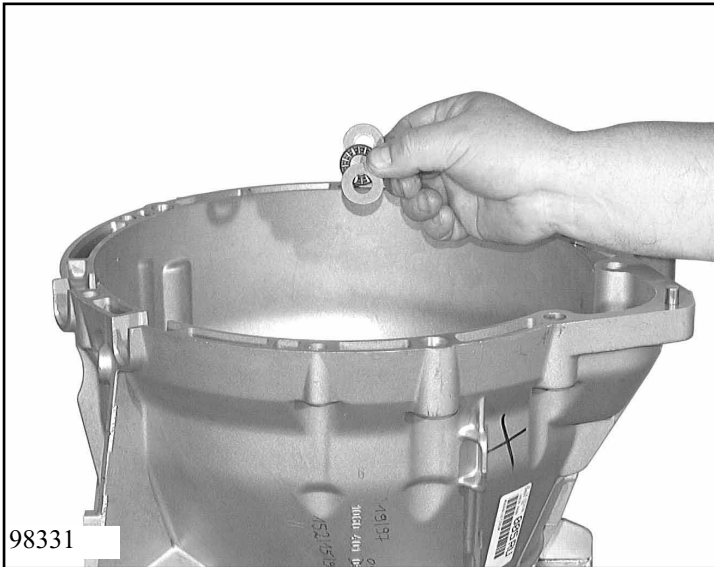

Insert thrust washer 32.200/110 , axial needle cage 32.200/120 and thrust washer 32.200/130 over the journal of the intermediate shaft.



### 3.5 Input assembly

#### 3.5.1 Clutch E

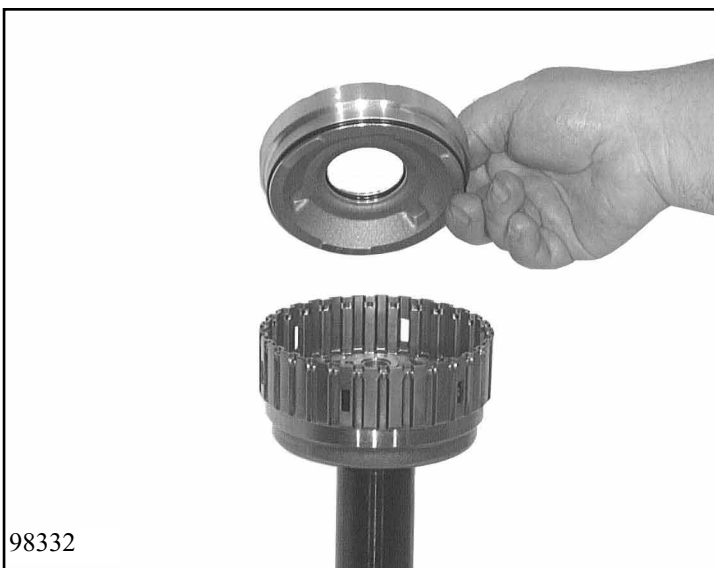
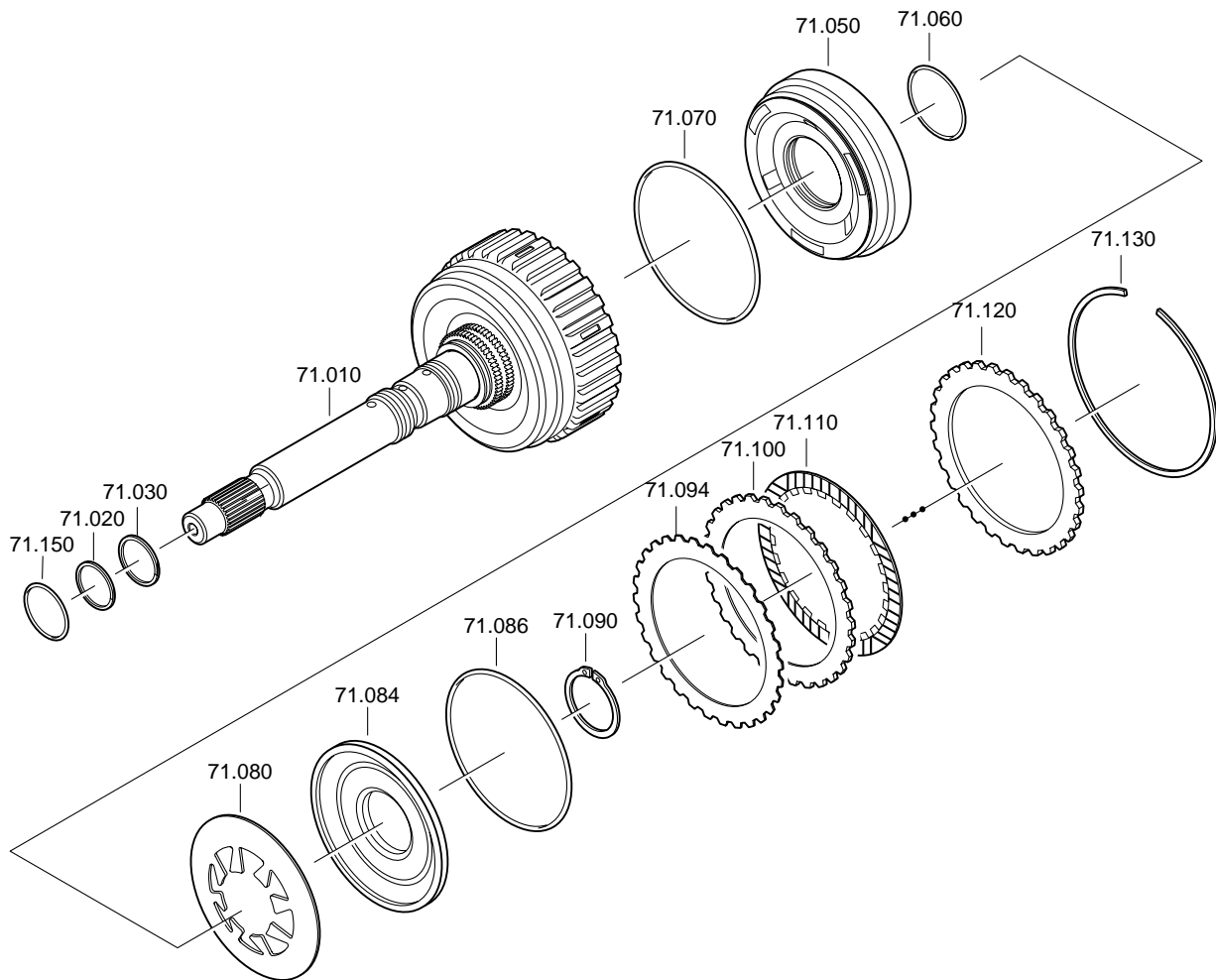

Pull new O-rings 71.060 and 71.070 onto piston E 71.050.  
Push piston E into cylinder E on input shaft 71.010.

98332

Place cup spring 71.080 with the edge of the cup facing upwards onto piston E.  
Pull a new O-ring 71.086 onto oil dam 71.084 and insert into piston E.



Push the oil dam down with assembly bracket 5x46 030 167 on a mandrel press and fit retaining ring 71.090 with suitable pliers.

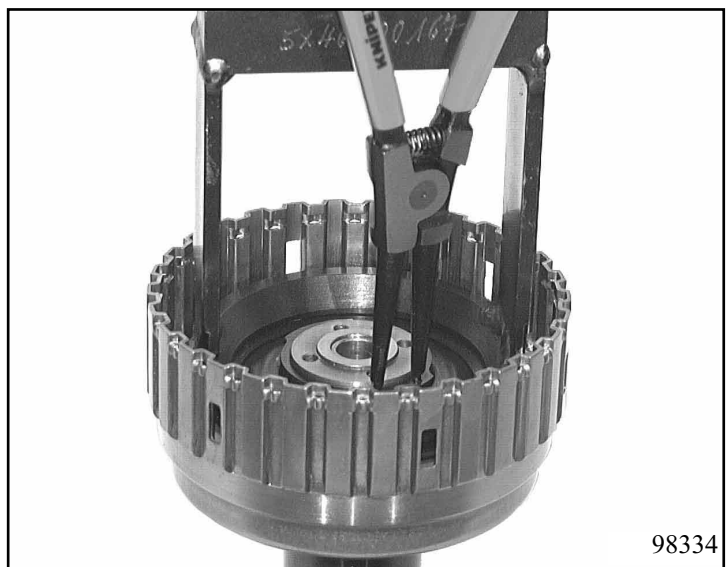

Insert complete disc assembly of clutch E, starting with spring disc 71.094.  
Then mount alternately steel discs 71.100 and lined discs 71.110.  
Mount final disc 71.120 and secure with snap ring 71.130.

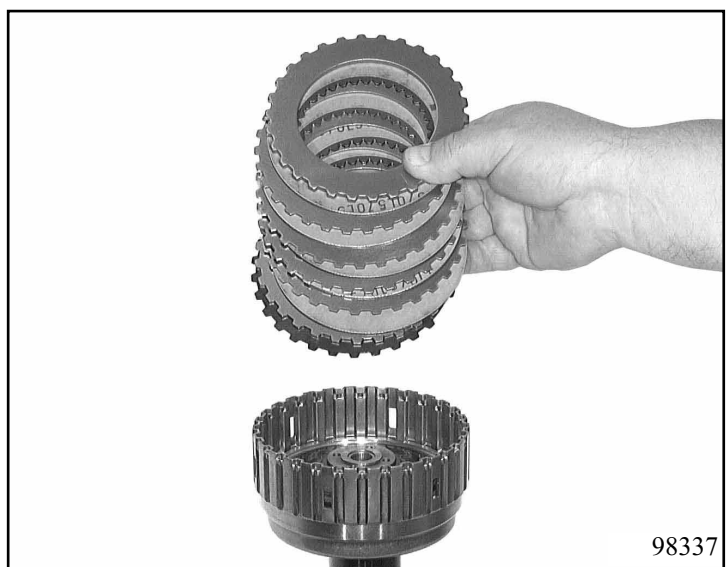

**Please note:**  
For adjustment, see **Chapter 1.4.4**





Mount 2 new rectangular-section rings 71.020 and 71.030 and new O-ring 71.150 on the input shaft.

### 3.5.2 Clutch A

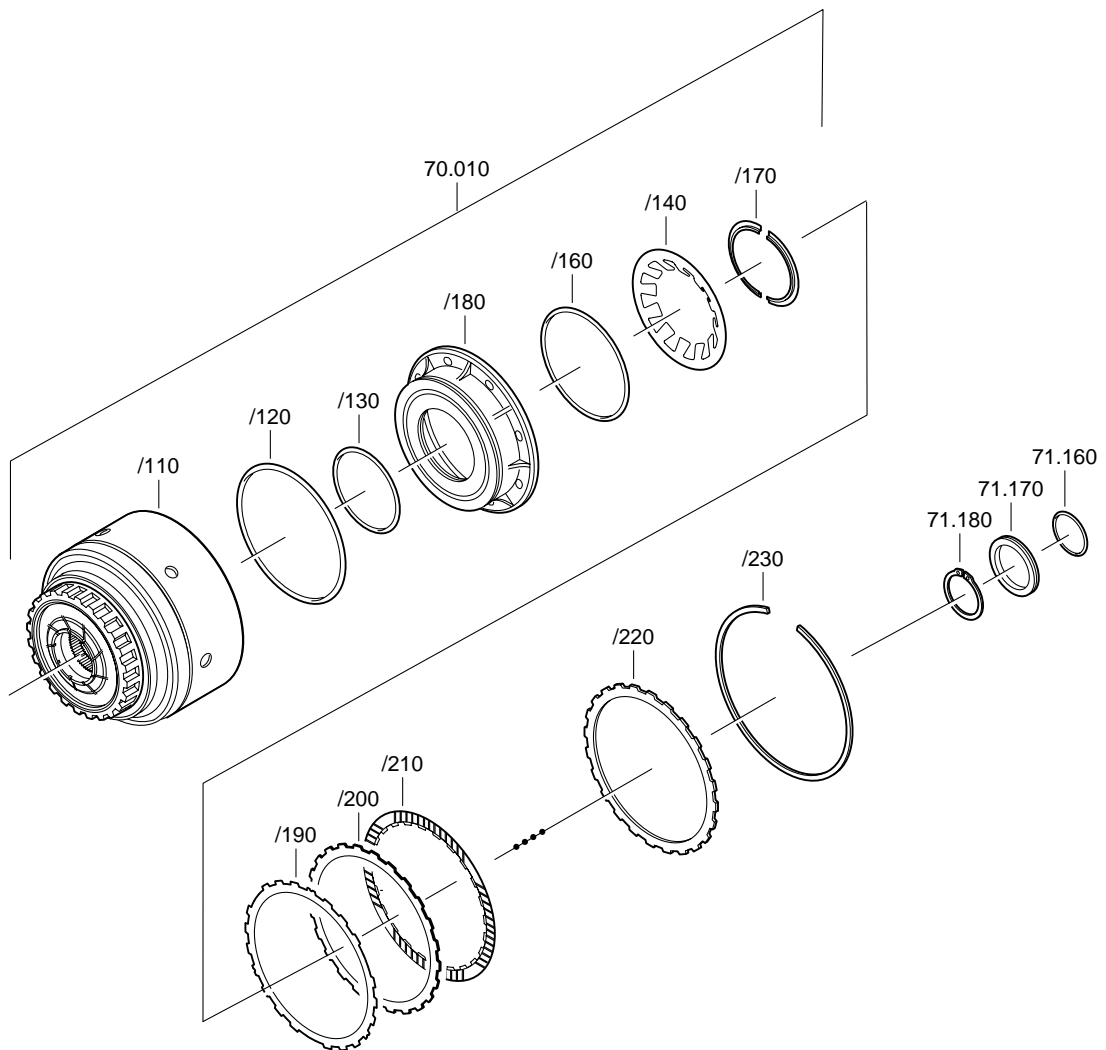

Pull new O-rings 70.010/120,  
70.010/130, 70.010/160 onto piston A  
70.010/180.

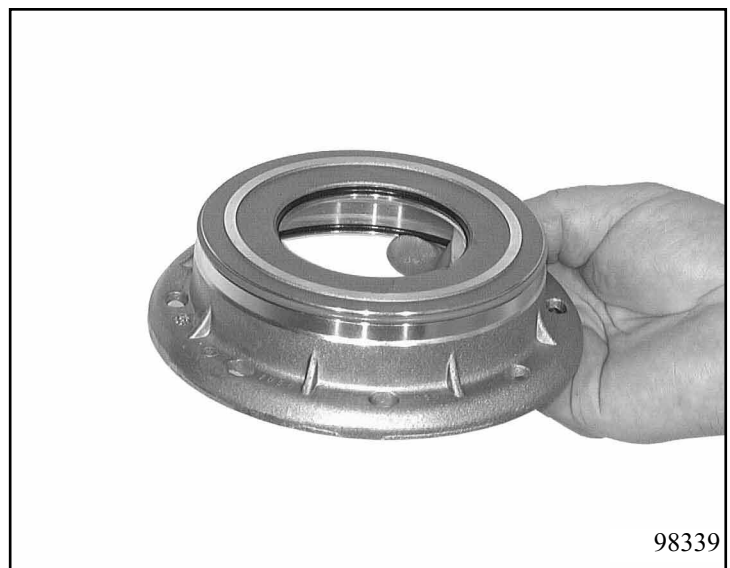

98339

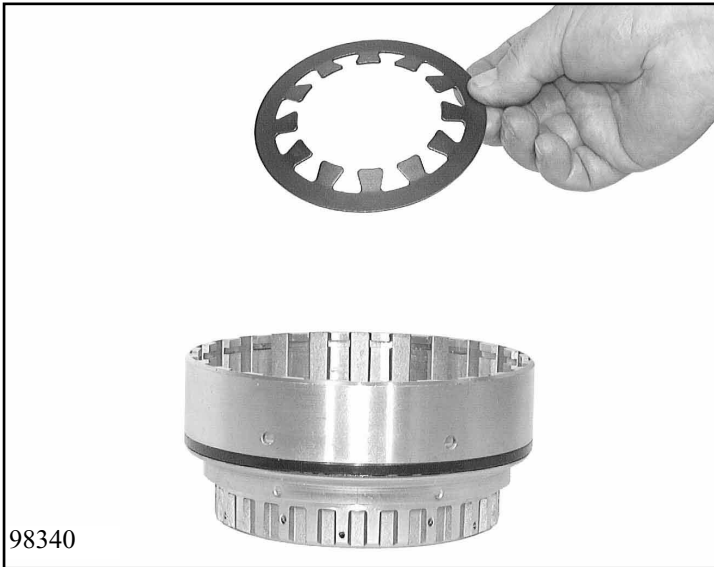

Push piston A into cylinder A 70.010/110 and insert cup spring 70.010/140 with the convex side upward.

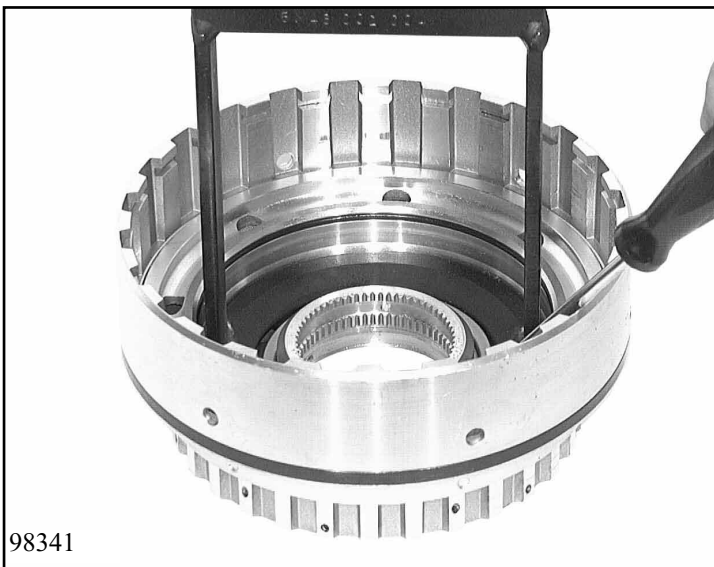

Press cup spring down with assembly device 5x46 002 004 and secure with split fixing washer 70.010/170.

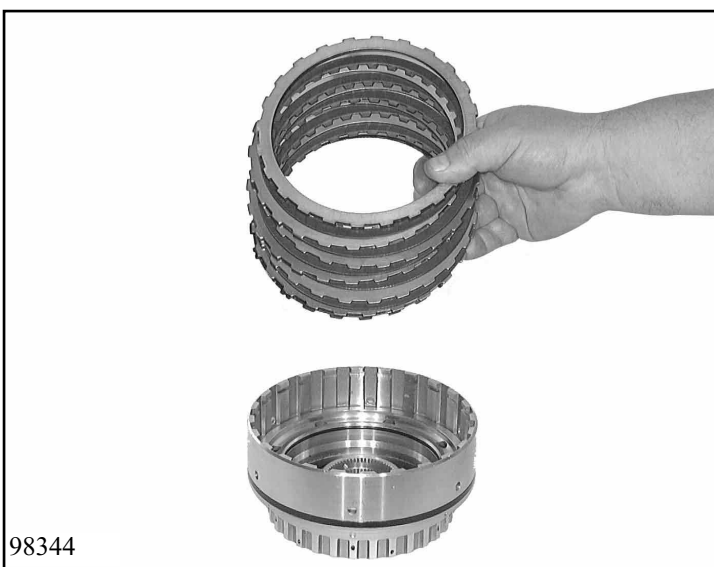

Insert complete disc pack of clutch A. Start with spring disc 70.010/190, followed alternately by outer discs 70.010/200 and lined discs 70.010/210. Add final disc 70.010/220 and secure with snap ring 70.010/230.

**Please note:**  
For adjustment, see **Chapter 1.4.5**

Pull O-ring 71.160 onto ring 71.170, insert into hub of cylinder A and push in until it stops.



Engage clutch A in splines via the input shaft and push in as far as the stop.  
Next push on ring with O-ring as far as the stop.  
Fix clutch A on input shaft by means of ground retaining ring 71.180.

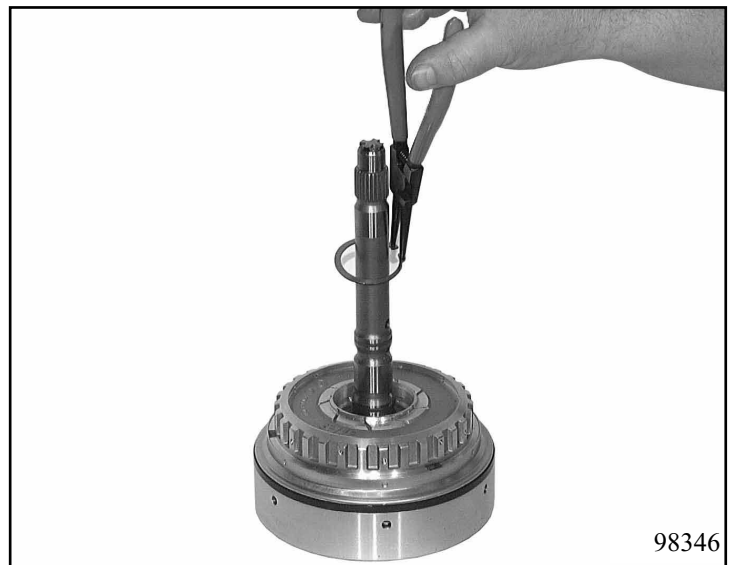

### 3.5.3 Clutch B

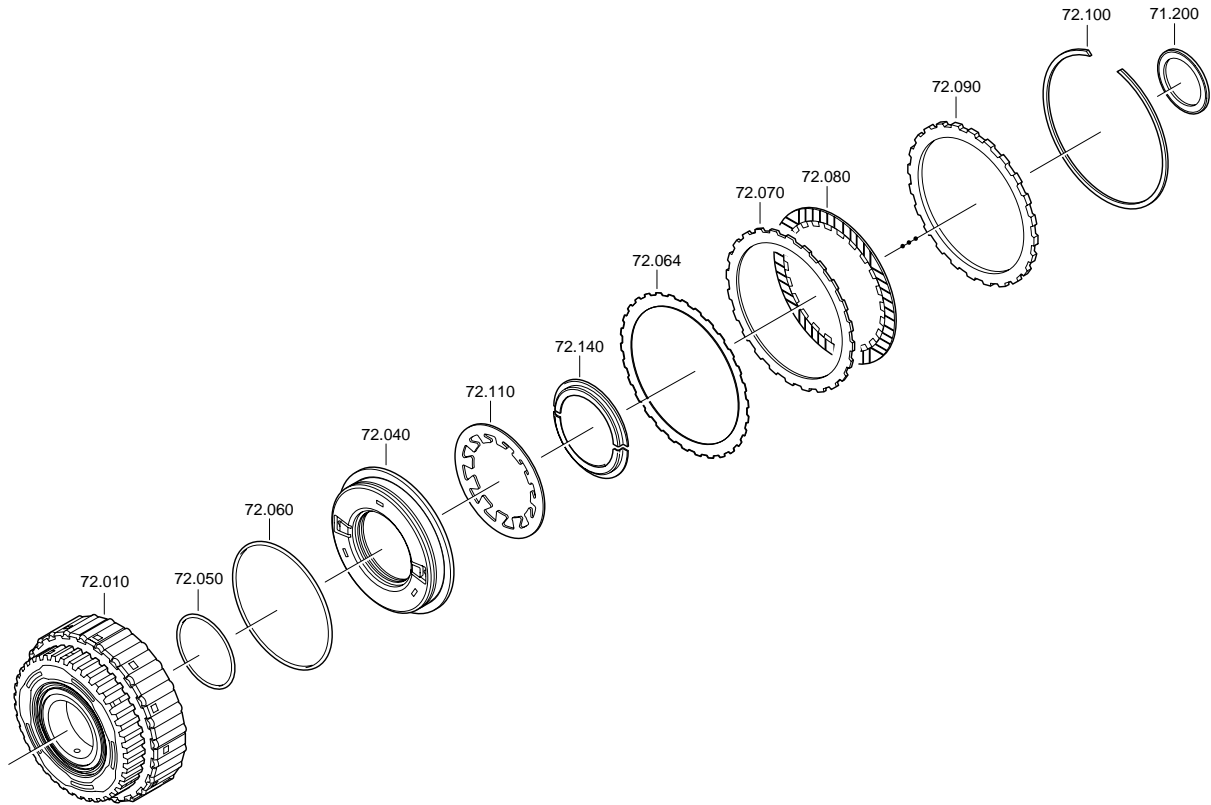

Pull 2 new O-rings 72.050, 72.060 onto piston B 72.040 and push into cylinder B 70.010.

98347

Insert cup spring 72.110, push down the cup spring with assembly device 5x46 002 005 and secure with split stop ring 72.140.



Insert clutch pack B.  
Start with spring disc 72.064, insert alternately steel discs 72.070 and lined discs 72.080.  
Place final disc 72.090 on top and secure with snap ring 72.100.

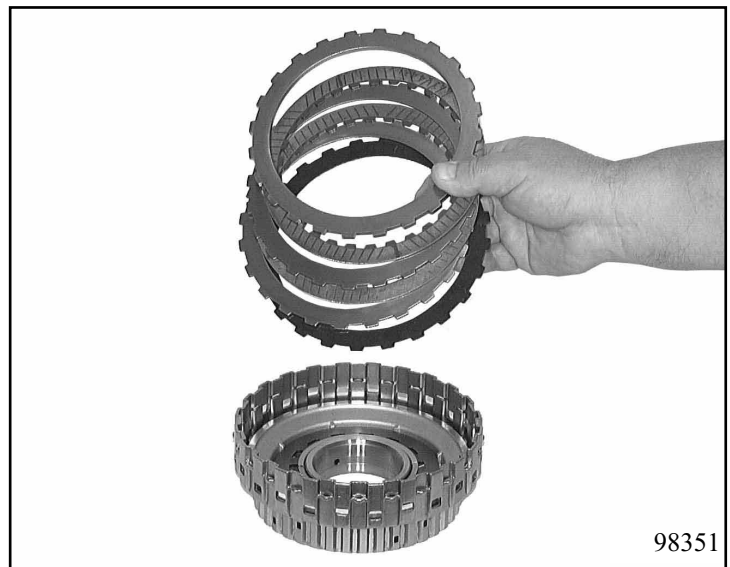

**Please note:**  
For adjustment, see **Chapter 1.4.6**

Place axial bearing 71.200 on cylinder A.  
Align lined discs of clutch B and insert over cylinder A, turning at the same time.



### 3.6 Oil supply with brake C

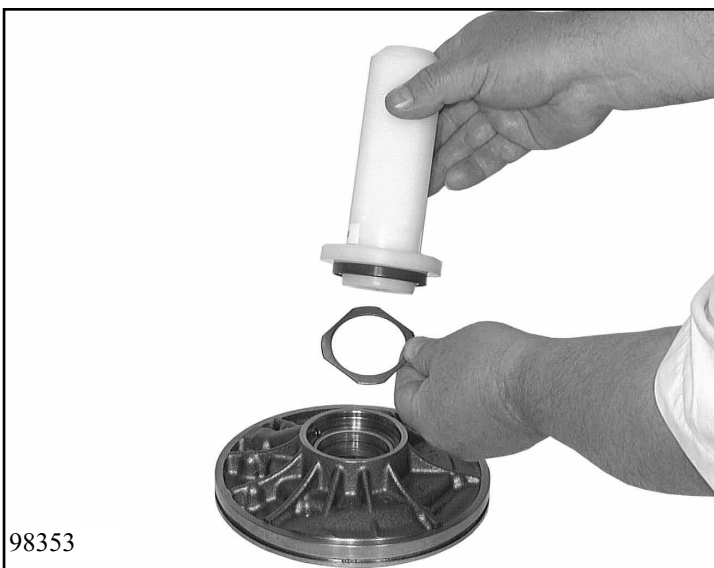
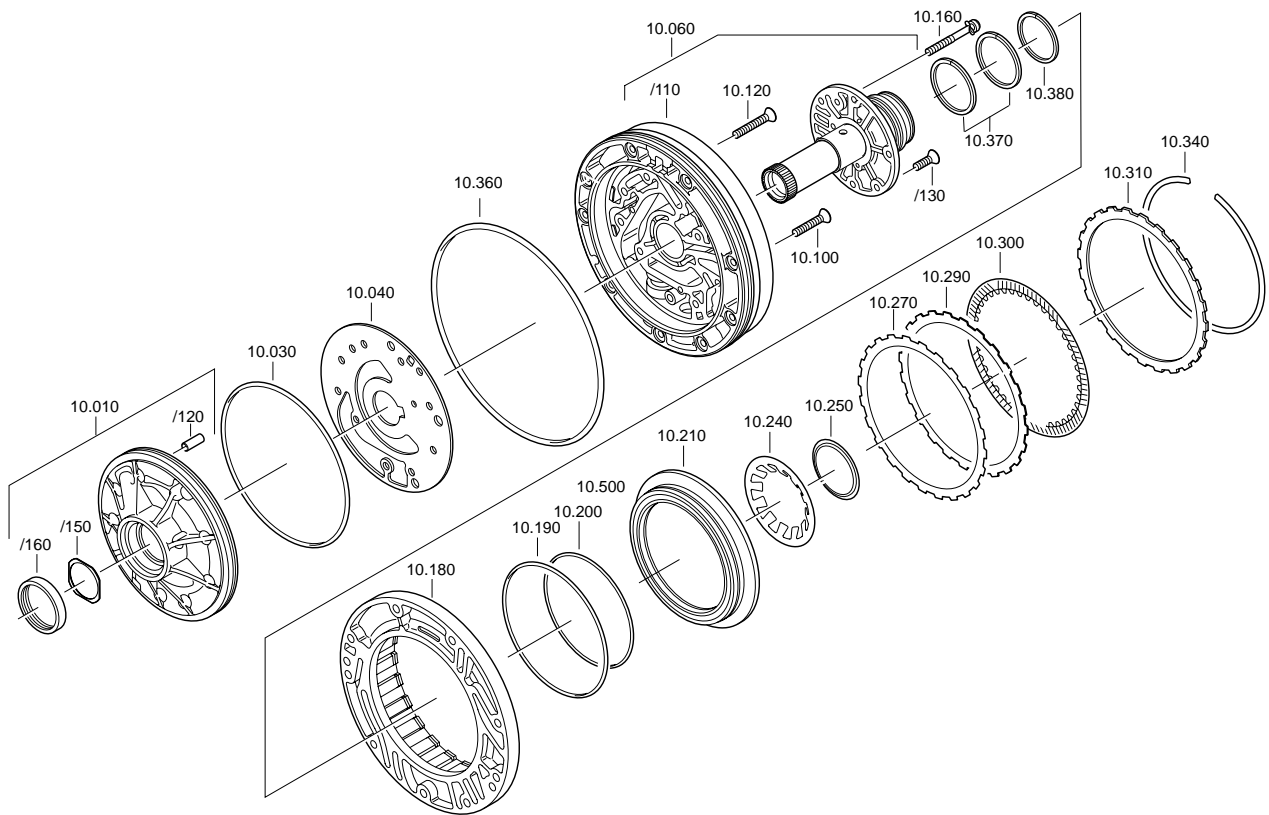

Insert disc 10.010/150 into the pump casing and mount shaft seal 10.010/160 using assembly sleeve 10.010/160.

98353

Re-assemble pump 10.010 in such a way that the marks on the pump impeller and the pump ring gear are at the top.



Insert centering sleeve 10.010/120 into pump casing and position intermediate plate 10.040.  
Then pull new O-ring 10.030 onto pump casing.



Screw 2 centering pins 5x46 001 007 into intermediate plate 10.060/110.  
Heat the intermediate plate to about 70 - 80° C at the seat for the stator shaft and insert stator shaft into the plate using the centering pins. Remove the centering pins.  
Screw the stator shaft loosely to the intermediate plate with 5 countersunk screws 10.060/130.





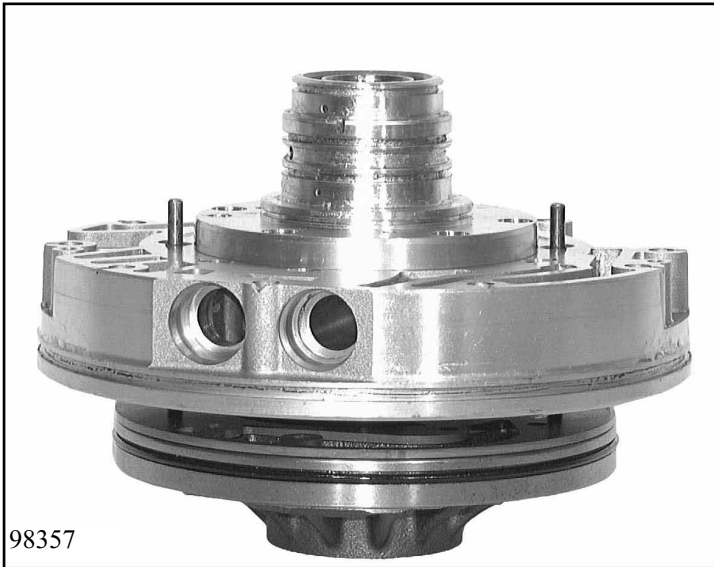

Twist 2 centering pins (M6) into the pump, place the intermediate plate over them and push in.

Remove the centering pins.

Loosely screw in 8 countersunk screws 10.100, 1 countersunk screw 10.120 and 1 machine screw 10.160.

**Important !**

Screw tightening instructions see **Chapter 1.3.1**

98357



Pull new O-ring 10.360 onto oil supply and 3 new rectangular-section rings 10.370, 10.380 onto the hub of the stator shaft.

Check that the pump runs easily with plug gauge 5x46 000 306.

98358



Place cylinder C 10.180 on oil supply and align.

Pull 2 new O-rings 10.190, 10.200 onto piston 10.210.

Press piston into cylinder C.

98359

Place cup spring 10.240 onto piston C, press down with assembly bracket 1 5x46 000 576 under a mandrel press and secure with split stop ring 10.250.

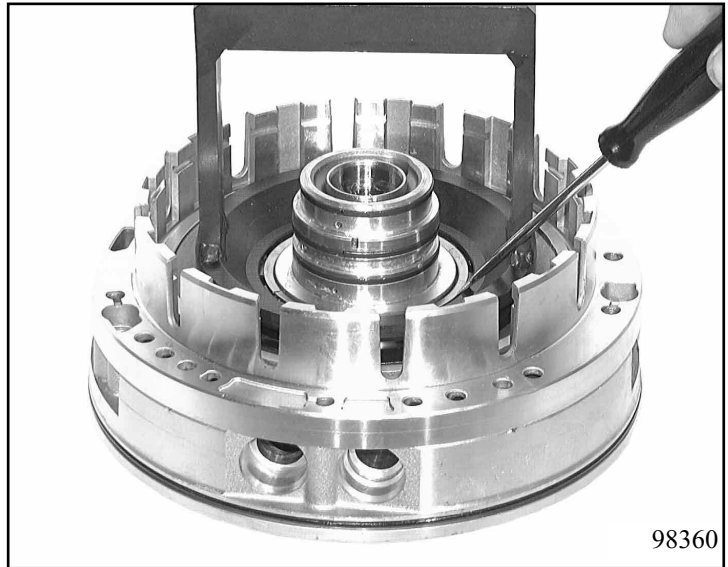

Insert complete disc assembly of brake C.  
Starting with spring disc 10.270, alternately insert steel discs 10.290 and lined discs 10.300, ending with a thick outer disc 10.310.  
Then secure with snap ring 10.340.

**Please note:**  
For adjustment, see **Chapter 1.4.7**



### 3.7 Input assembly with oil supply

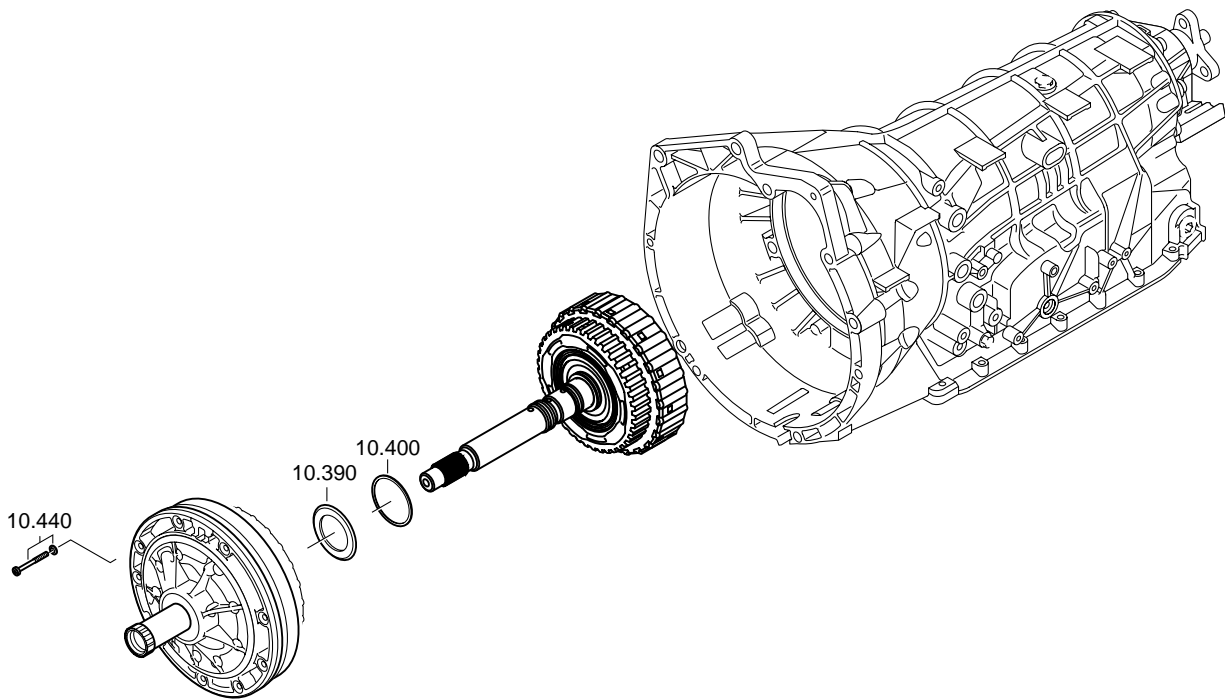

Place shim 10.400 on cylinder B.  
Stick angle washer/axial needle cage on stator shaft hub with a little white petroleum jelly.

#### **Important !**

For necessary adjustments, we suggest the thinnest shim from the O.T.K.

Then insert correct shim as determined during adjustment.

Align lined discs, brake C, with tool 5x46 002 007 and wedge with plastic wedge 5x46 002 007.  
Place oil supply over input shaft until lined discs are completely inside disc carrier C.

**Important!**

Remove plastic wedge again.



Clamp assembly device 5x46 002 010 onto the input shaft, flush with the stator shaft.



Now insert the complete unit in the transmission housing, turning it as you do so, until lined discs of clutch A and E are completely inserted, and press into end position with firm pressure on the device. At the same time, centre the oil supply over the transmission with centering pin 5x46 002 007 in such a way that the bore of the oil-supply flow control valve is in alignment with the hole in the transmission housing.

**Please note:**

The driving splines of the cup must engage fully in cylinder B. To ensure this, turn both the cup and the input shaft.

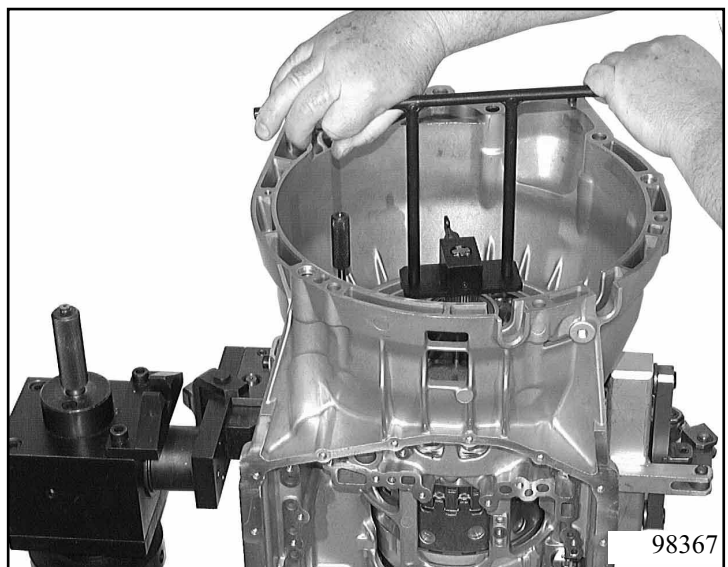

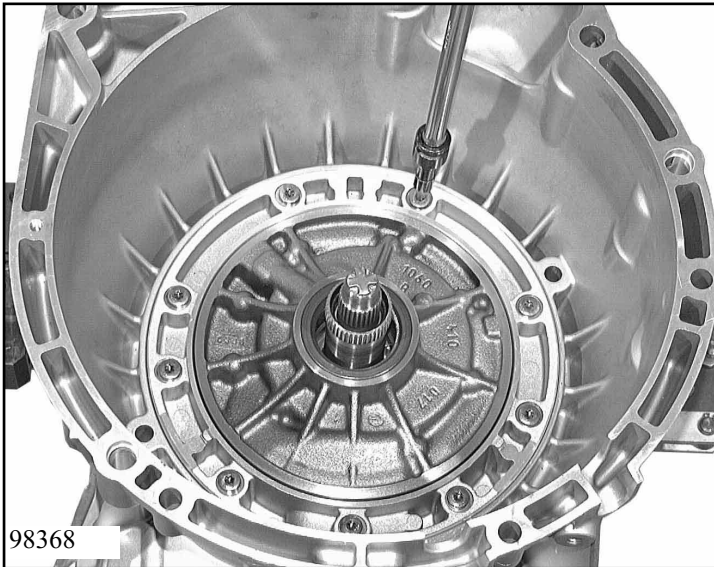

Fasten the oil supply with 9 screws 10.440 and new Usit-rings. Turn the transmission so that the oil pan is at the top.

(For tightening torques, see Chapter 1.5)

**Please note:**  
For adjustment, see Chapter 1.4.9



### 3.8 Automatic control unit, flow control valve, oil filter and oil pan

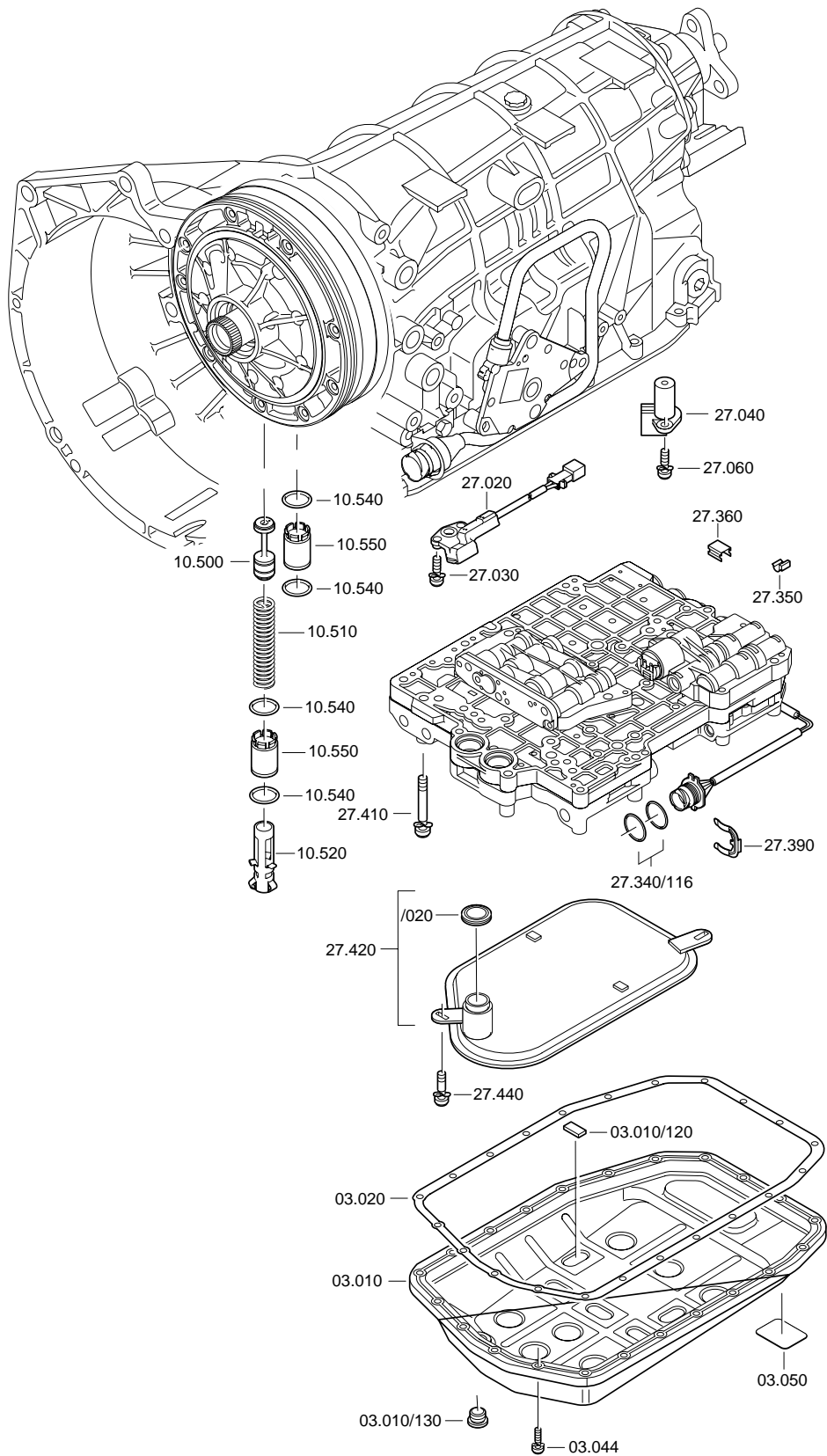

Check that all the clutches and brakes work using test plate 5p04 000 208 and compressed air.  
Remove the test plate after testing.

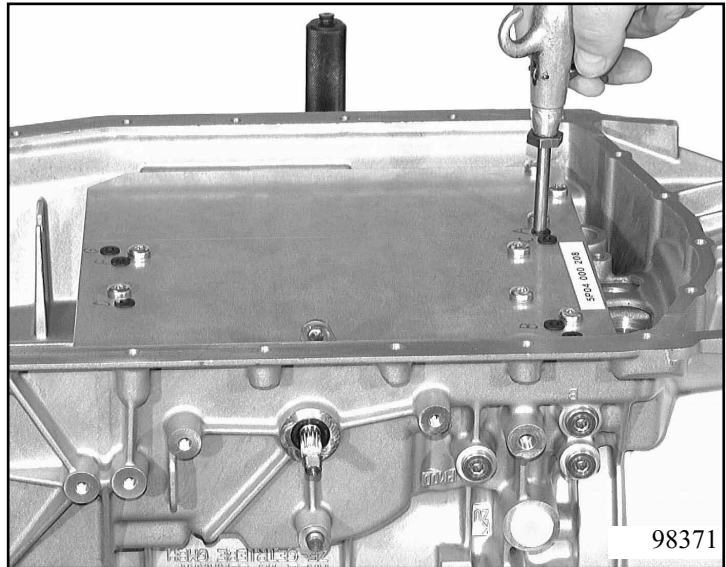

**Important!**

Screw the test-plate screws to the transmission housing at 8 Nm.

Insert piston 10.500 into bore of flow control valve.  
Then fit new tube 10.550 with 2 new O-rings 10.540 into this bore. Press spring 10.510 with sleeve 10.520 into tube and twist until it locks.  
Press in new tube 10.550 with 2 new O-rings 10.540 into the adjacent bore.

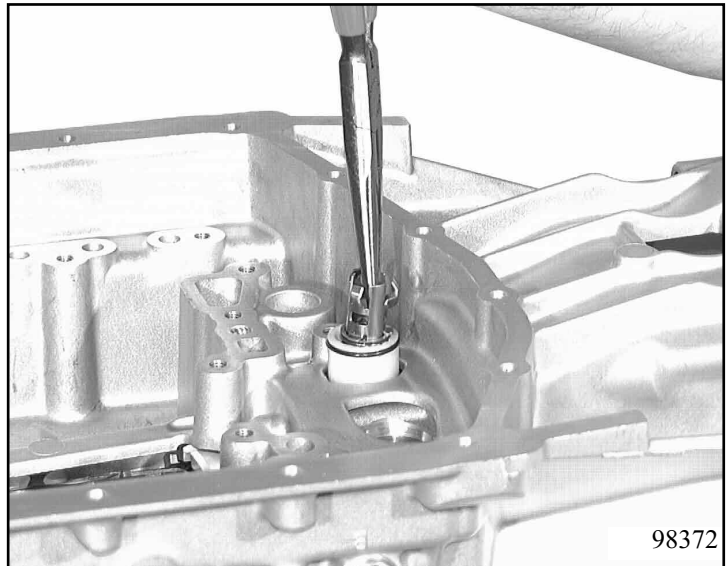

**Please note:**

On more recent transmissions (Transm. No. >7735), clip retaining clips for the cable 27.350 and 27.360 of the Hall-effect sensor to corresponding webs on the control unit.

Place the complete control unit on at an angle.  
Fasten Hall-effect sensor 27.020 using screw 27.030 and clip connecting cable to housing web.

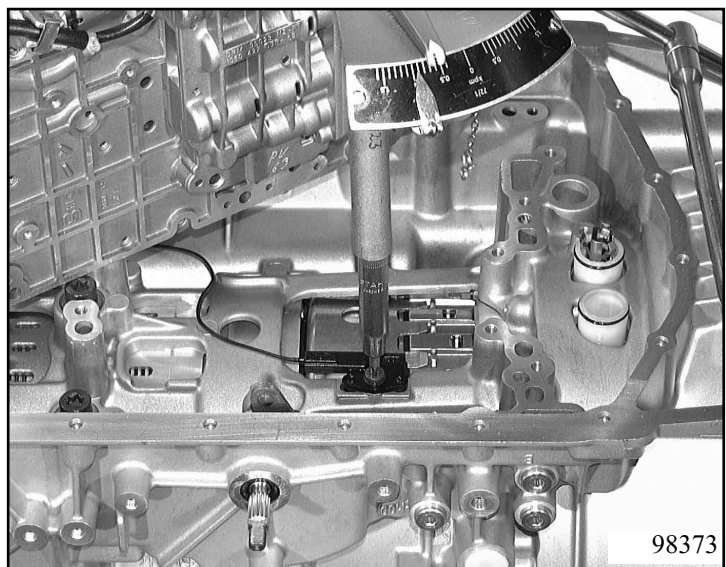

(For tightening torques, see Chapter 1.5)



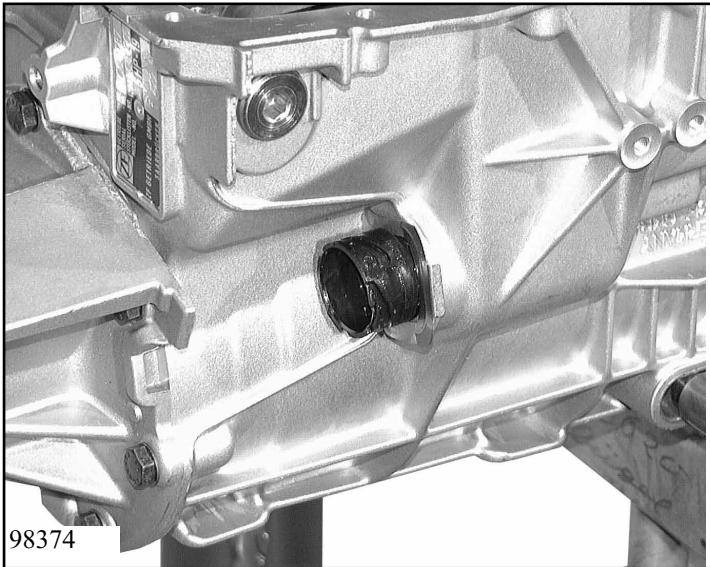

Pull 2 new O-rings 27.340/116 onto wiring harness plug 27.340.  
 Insert plug in hole, engage guide pin in slot and fix with tab washer 27.390.

Lay the cable for the Hall-effect sensor as close as possible to the wall of the housing to prevent it from being trapped.

**Please note:**

On more recent transmissions (Transm. No. > 7735), the cable of the Hall-effect sensor is pressed into the cable clips (see Service Bulletin).

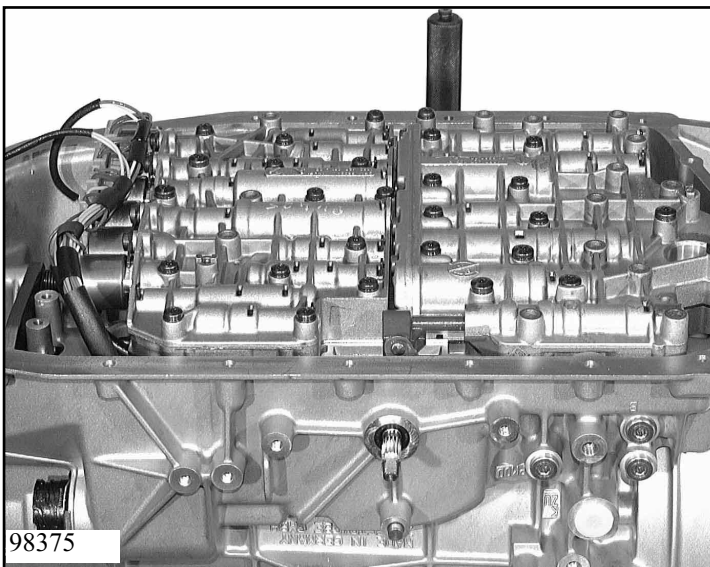

Select "N".  
 Align control unit and press on by hand.

**Important!**

Detent disc pin must be inserted correctly into the slot in the manual valve and the guide pin must be inserted correctly in the transmission housing.

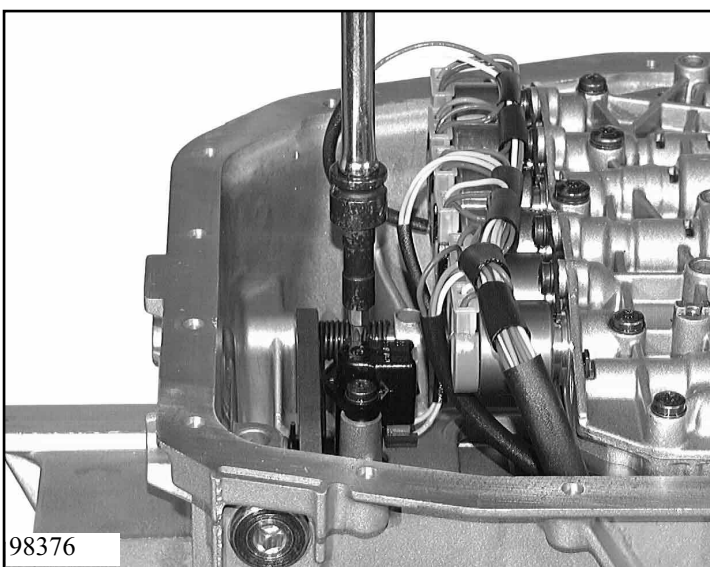

Insert inductive transmitter 27.040 in the hole provided and fasten it with 2 screws 27.060.

(For tightening torques, see Chapter 1.5)

Fix the automatic control unit with 14 screws 27.410.

(For tightening torques, see Chapter 1.5)

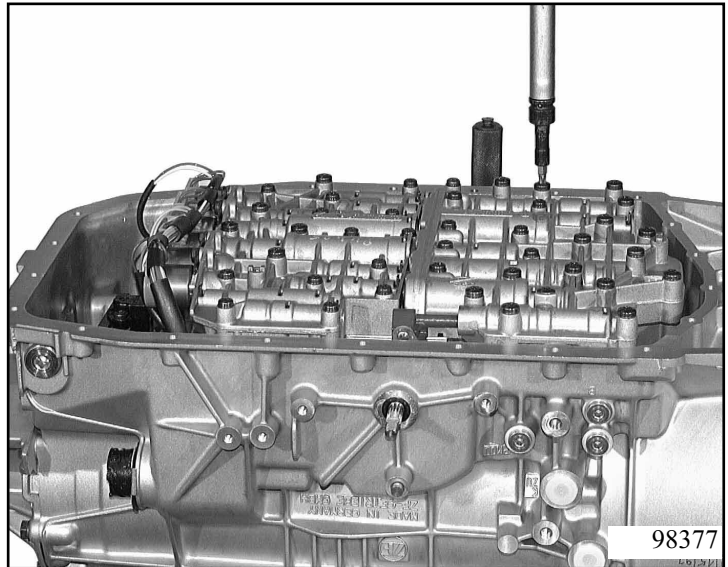

Place oil filter 27.420 on control unit with new sealing ring 27.420/020 and fasten with 2 screws 27.440.

(For tightening torques, see Chapter 1.5)

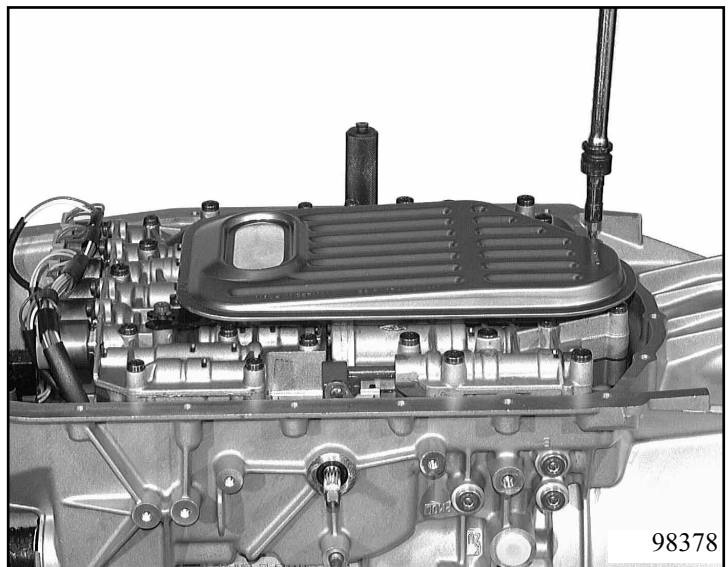

Insert 8 magnets 03.010/120 into recesses in the oil pan 03.010 - all around the oil filter intake opening.  
Place a new, lightly oiled paper gasket 03.020 on the sealing face of the transmission housing. Working diagonally, fasten the oil pan with 22 screws 03.044.

(For tightening torques, see Chapter 1.5)

**Please note:**

For BMW, make sure that the stick-on label 03.050 has been applied to the oil pan.

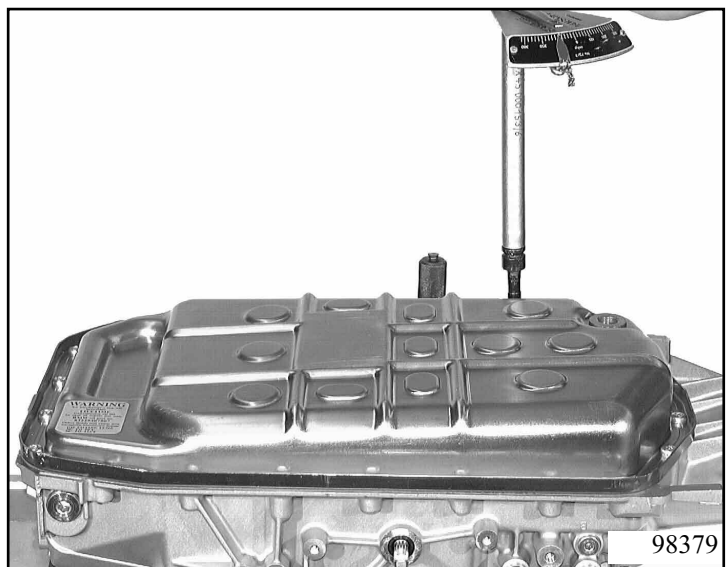

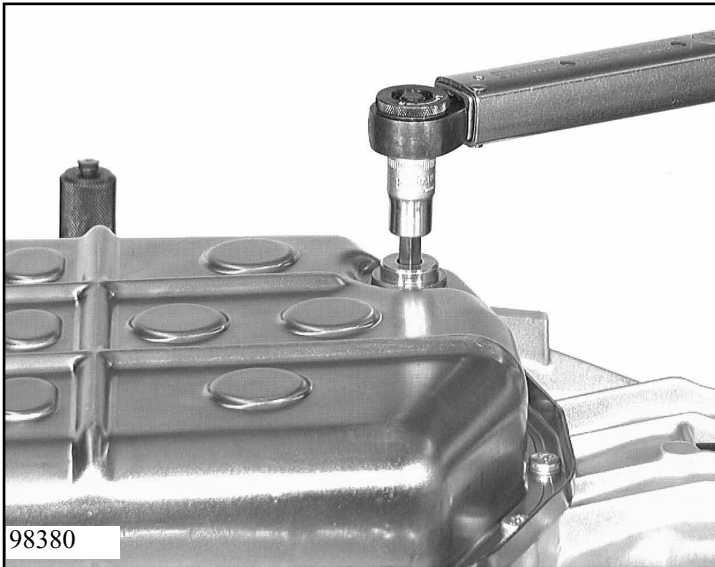

Screw new oil drain plug 03.010/130 into the oil pan.

(For tightening torques, see Chapter 1.5)



### 3.9 Position switch and converter

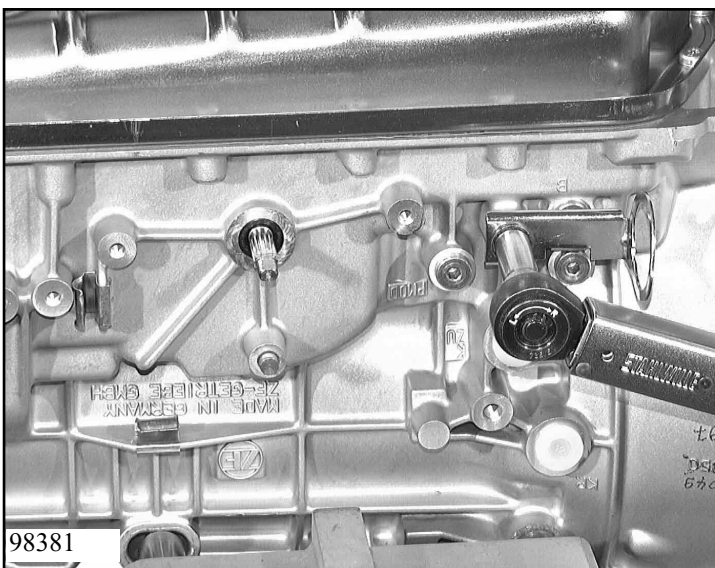
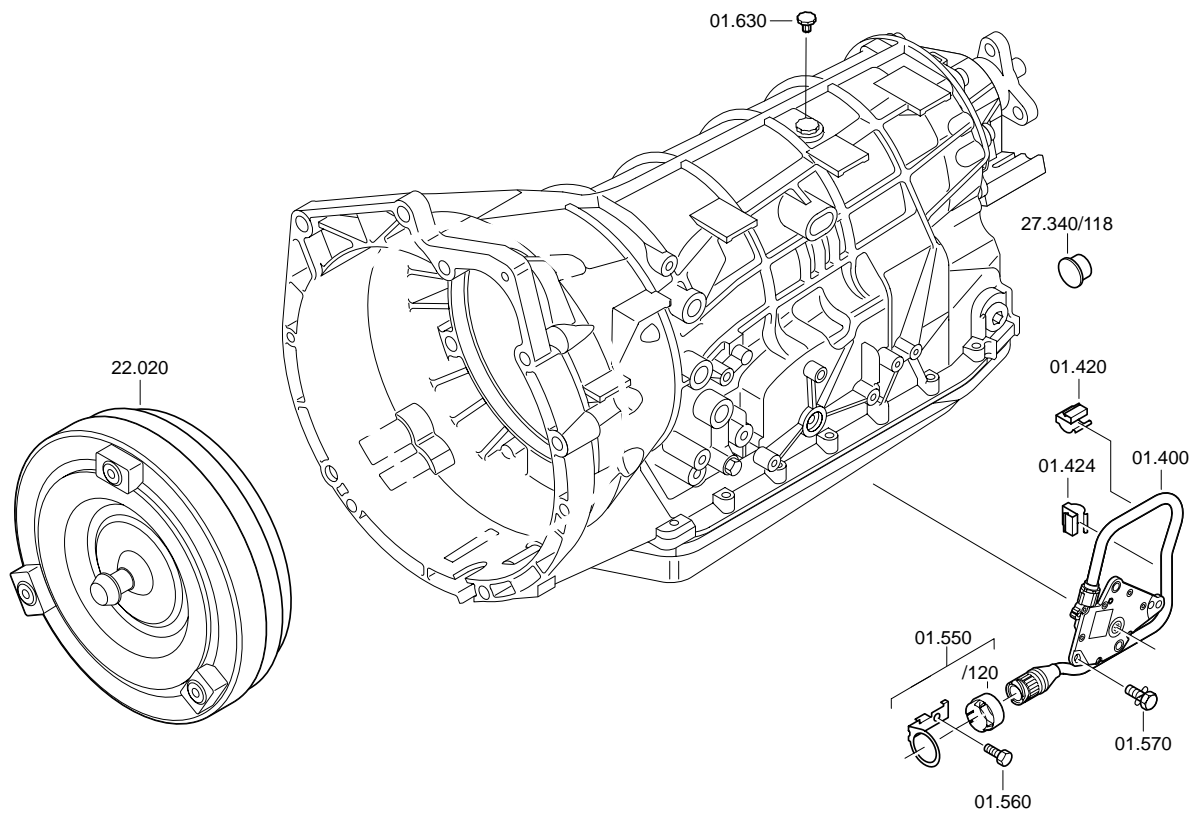

Attach cable clips 01.420, 01.424 to webs.

Screw holder 01.550 to transmission housing using screw 01.560.

Move selector shaft to the “N” position.

(For tightening torques, see Chapter 1.5)

Slide the position switch along the selector shaft until the locating pin of the transmission housing enters the hole in the switch.

Make sure that the cable runs behind the position switch.

Clip cable into the cable clips, insert the plug into the holder and lock.

Fasten position switch with 2 screws 01.570.

(For tightening torques, see Chapter 1.5)

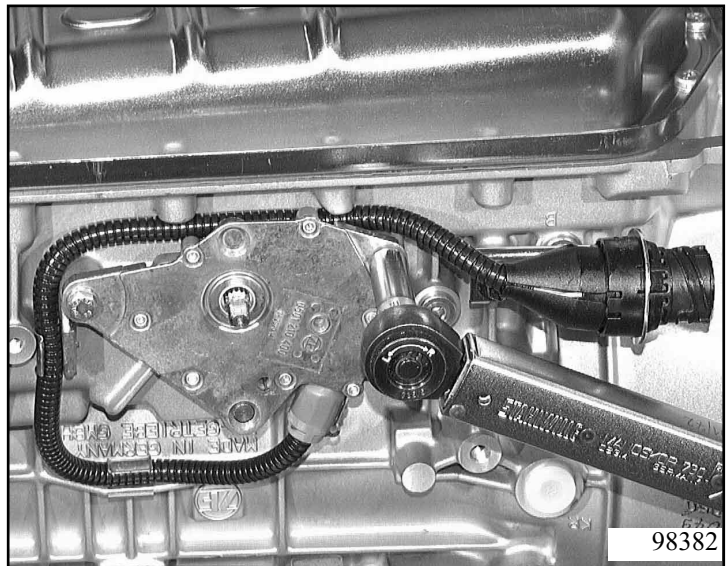

Screw 2 handles 5x56 000 090 into the converter and carefully insert the converter 22.020.

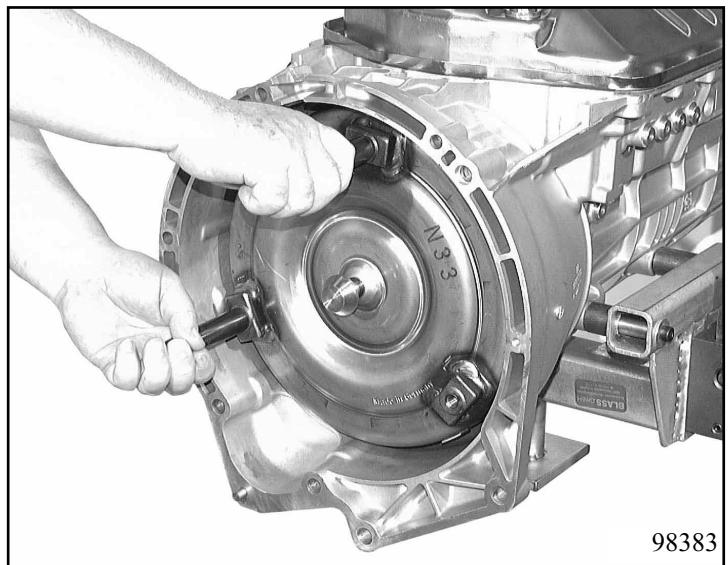

Turn the transmission by 90° and turn the converter carefully backward and forward until the pump drive journals have engaged.

Remove the handles.

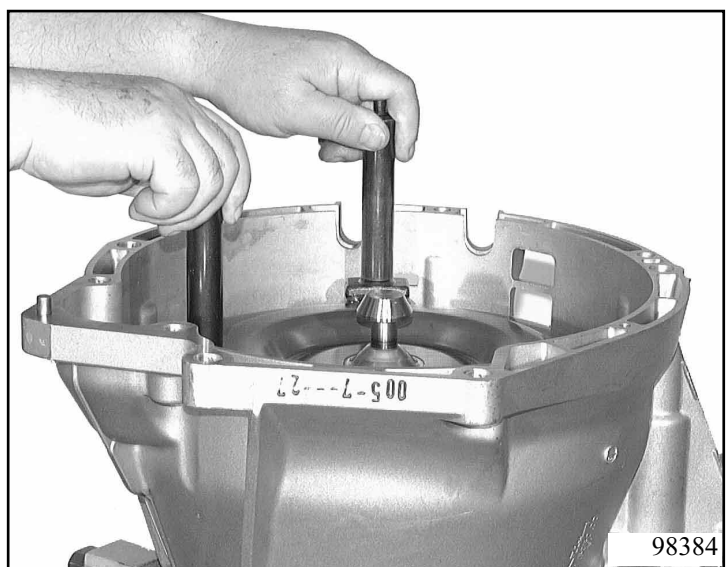

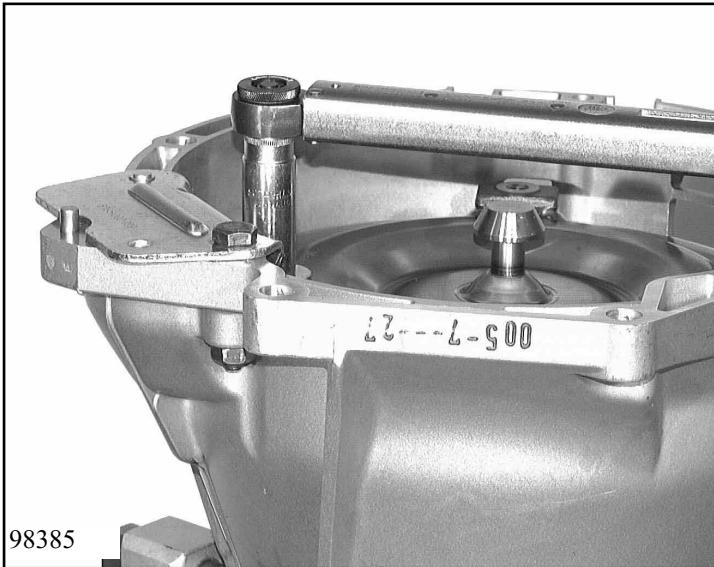

Screw the converter retaining bracket 5T95 000 099 to the converter and the transmission housing with 2 screws.

(For tightening torques, see Chapter 1.5)

**Important!**

The converter fastening screw must not be too long - recommended length 16 mm. Otherwise the converter will be damaged and will not operate correctly.

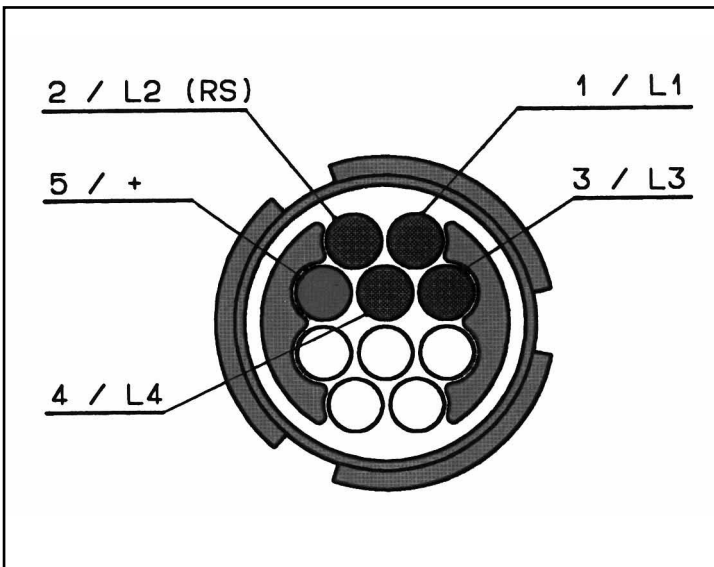

Check the switch with a multimeter (Ohm setting), referring to the table.

**Codiertabelle**

	P	Z1	R	Z2	N	Z2	D	Z3	4	3	2
<b>L1</b>	1	1	1	1	1	1	0	0	0	0	1
<b>L2</b>	1	0	0	0	1	0	0	0	0	0	0
<b>L3</b>	0	0	0	1	1	1	1	0	0	1	1
<b>L4</b>	1	1	0	0	0	0	0	0	1	1	1
<b>RF</b>	0	0	1	0	0	0	0	0	0	0	0

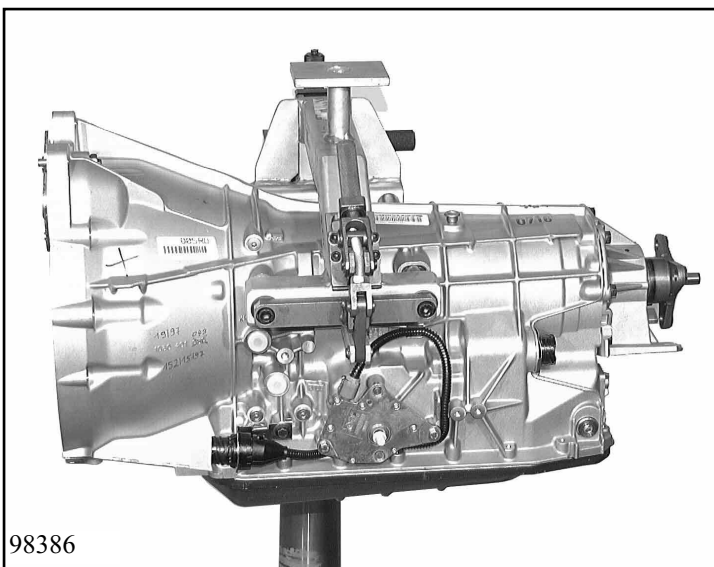

Insert breather cover 01.630 into the breather.

Then fit all the transport plugs/caps:

- 1 transport plug for selector shaft
- 1 screw plug 27.340/118 on EGS wiring harness

