

TIMKEN

SOLUTIONS FOR THE AUTOMOTIVE INDUSTRY

VOLUME 2 • ISSUE 1

TECH TIPS

Maximizing bearing performance and life remains an objective throughout The Timken Company, from design teams and manufacturing associates to our field sales team and distributors. TechTips helps you install and maintain Timken® bearings, seals and components to maximize the life and performance of your bearings and the systems in which they operate. For more information regarding Timken automotive products and services, visit www.timken.com or contact your local Timken distributor.

PROPER TAPERED BEARING SETTINGS

The amount of end play or preload existing in a mounted pair of bearings is critical to performance. If incorrectly set, bearings may prematurely damage, and seals, brake components and tire operation may also be affected.

In addition, improper bearing setting can negatively impact factory settings of camber and toe. The Timken Company recommends installing all bearings to proper setting specifications to avoid issues.

SETTING FOR PASSENGER CAR NON-DRIVEN WHEEL

Several mounting methods for tapered single roller bearings exist, some are more common than others. One of the most popular methods is mounting and adjusting bearing setting with a bottle-cap stamping, hexagonal nut, cotter pin and threaded shaft (see Figure 1).

This approach is typically used on passenger car front wheels in conjunction with a hardened tongue washer between the outboard bearing's inner ring and the adjusting nut.

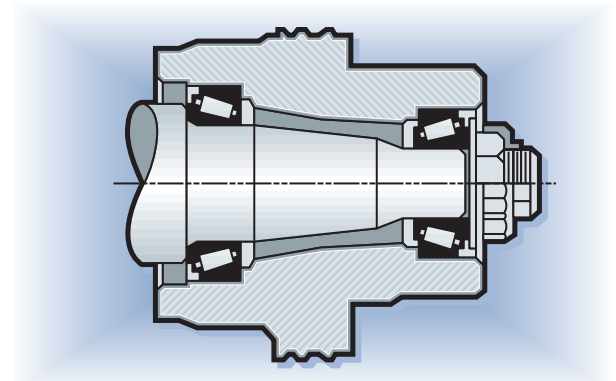

Figure 1: Passenger car non-driven wheel setting method

To adjust the setting of this bearing:

- Step 1:** Tighten the nut while turning the hub. When there is a slight bind on the bearing, the parts are seated correctly.
- Step 2:** Back the nut off 1/6 to 1/4 of a turn or sufficiently to allow .001" to .007" end play.
Note: Failure to back off adjusting nut could cause bearing to run hot and be damaged. Wheel could lock or separate.
- Step 3:** Place the bottle-cap-type stamping over the nut and insert the cotter pin to prevent the nut from backing off.

SETTING FOR INDEPENDENT SUSPENSION REAR AXLES

Hardened surface nuts, tongue washers and outer-jam nuts or lock nuts are commonly used for wheels with full floating rear axles and some front-wheel applications (see Figure 2).

To adjust the setting of this bearing:

Step 1: Tighten the nut while turning the hub. When there is a slight bind on the bearing, the parts are seated correctly.

Step 2: Back the nut off 1/6 to 1/4 of a turn or sufficiently to allow .001" to .007" end play.

Note: Failure to back off adjusting nut could cause bearing to run hot and be damaged. Wheel could lock or separate.

Step 3: Tighten the jam nut to remove the thread clearance and to prevent the nut from backing off.

Proper bearing setting practices ensure maximum performance and life for bearings and all related

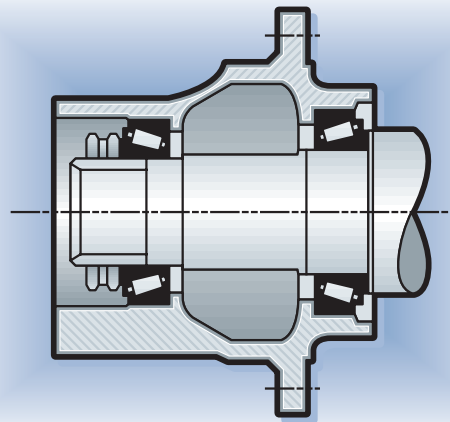

Figure 2: Independent suspension rear axle setting method

wheel components. Contact your Timken sales representative or distributor with additional bearing setting questions.

Additional information regarding Timken bearings, seals and hub assemblies can be found at www.timken.com or by calling 1-800-223-1954 and asking for Aftermarket.

WARNING: Proper maintenance and handling practices are critical. Failure to follow installation instructions and maintain proper lubrication can result in equipment failure, creating a risk of serious bodily harm.

Never spin a bearing with compressed air. The rollers may be forcefully expelled, creating a risk of serious bodily harm.



"Educating the consumer about the benefits of regular vehicle care, maintenance and repair."

Timken® is the registered trademark of
The Timken Company
www.timken.com

TIMKEN

WORLDWIDE LEADER IN BEARINGS AND STEEL